

Air Force Institute of Technology

AFIT Scholar

Theses and Dissertations

Student Graduate Works

3-4-2002

Interim Brigade Combat Team (IBCT) Munitions Distribution Study

Todd S. Bertulis

Follow this and additional works at: <https://scholar.afit.edu/etd>



Part of the [Operations and Supply Chain Management Commons](#)

Recommended Citation

Bertulis, Todd S., "Interim Brigade Combat Team (IBCT) Munitions Distribution Study" (2002). *Theses and Dissertations*. 4479.

<https://scholar.afit.edu/etd/4479>

This Thesis is brought to you for free and open access by the Student Graduate Works at AFIT Scholar. It has been accepted for inclusion in Theses and Dissertations by an authorized administrator of AFIT Scholar. For more information, please contact richard.mansfield@afit.edu.



INTERIM BRIGADE COMBAT TEAM (IBCT)

MUNITIONS DISTRIBUTION STUDY

THESIS

Todd S. Bertulis, Captain, USA

AFIT/GLM/ENS/02-02

DEPARTMENT OF THE AIR FORCE
AIR UNIVERSITY

AIR FORCE INSTITUTE OF TECHNOLOGY

Wright-Patterson Air Force Base, Ohio

APPROVED FOR PUBLIC RELEASE; DISTRIBUTION UNLIMITED

The views expressed in this thesis are those of the author and do not reflect the official policy or position of the United States Air Force, Department of Defense, or the U.S. Government.

AFIT/GLM/ENS/02-02

INTERIM BRIGADE COMBAT TEAM (IBCT)
MUNITIONS DISTRIBUTION STUDY

THESIS

Presented to the Faculty

Department of Operational Sciences

Graduate School of Engineering and Management

Air Force Institute of Technology

Air University

Air Education and Training Command

In Partial Fulfillment of the Requirements for the
Degree of Master of Science in Logistics Management

Todd S. Bertulis, B. S.

Captain, United States Army

APPROVED FOR PUBLIC RELEASE; DISTRIBUTION UNLIMITED

Acknowledgments

I would like to take this opportunity to thank my advisor LtCol J.O. Miller. His generous guidance, patience, and enthusiasm helped me through the thesis journey. Without his help this work could not have been possible. I am also grateful to COL William Nanry for keeping me focused and in a “green” state of mind throughout the research process. Special thanks is owed to LtCol (Select) Stephen Swartz who helped me with several sections of this thesis, but more importantly, worked extensively with me to construct an outstanding logistics management program here at the Air Force Institute of Technology.

I would also like to thank my sponsors from the Army’s Combined Arms Support Command at Fort Lee, Virginia. MAJ Greg Graves, Mr. Howard Burnett, MAJ James Phelps and Mr. Jeff Higgins. Thank you gentlemen for all your support. I look forward to serving with you again.

I am also indebted to the many great logistics professionals who spent their valuable time explaining the processes and procedures associated with ammunition management and distribution for our Army. Special thanks to Mr. Dave Hale, MAJ Kenneth Ellison, Mr. Tim Fulton, CW2 Kevin Cattran, LTC Bruce Koch, and Mr. Robert Colclough for guiding me through the learning process as my subject matter experts. I realize your time was precious, but information was always readily available for the asking.

Finally, I extend my appreciation to each of my classmates. Thank you for the support, teamwork, and motivation. I learned more than I could ever have imagined during the program and I attribute much of it to your professionalism and willingness to share knowledge. It has been my distinct pleasure to serve with you during the last 20 months. God bless you all.

Table of Contents

	Page
Acknowledgments.....	iv
List of Figures	vii
List of Tables.....	ix
Abstract	x
I. Introduction	1
The Post Cold-War Environment.....	1
The Army’s Transformation and Revolution	2
The Interim Brigade Combat Team	4
Scope of Research	7
Problem Statement	8
Research Objective.....	9
Outline of Thesis	9
II. Literature Review.....	11
Introduction	11
Simulation of Supply Chains.....	11
Arena Simulation Software	14
Military Application of Simulations	15
Supporting the IBCT	18
Combat Service Support Enablers.....	20
The Ammunition Transfer Point Introduced.....	23
Defining Throughput.....	25
Summary	27
III. Methodology	29
Introduction	29
The System of Interest—The Ammunition Transfer Point.....	29
Formulating the Problem.....	33
Performance Measures of Interest.....	34
The Conceptual Model.....	34
Model Development and Assumptions	37
General Problem Framework.....	37
CROP Arrival Process.....	39
ATP Operation.....	41
Delivery Process.....	43
Supporting Logic.....	46

Sources of Variation and Assigned Stream.....	50
Summary	51
IV. Experimental Design, Results, and Analysis	52
Overview	52
Performance Measures for the ATP.....	52
Base Case Model Results	54
Experimental Design	57
Analysis of Variance	59
The Results – Average Throughput as Response Variable.....	60
The Results – Average Short Tons Delivered as the Response Variable.....	64
The Results – Mean Maximum CROPs Stored as the Response Variable	66
Overall Findings.....	71
V. Conclusions and Recommendations.....	74
Overview of Research	74
Relevance of the Research	75
Results of the Research	76
Future Research.....	78
Appendix A. The Arena Simulation Model	80
Appendix B. Model Distances	92
Appendix C. IBCT/Objective Force Acronyms and Abbreviation Helper	93
Bibliography.....	97
Vita	100

List of Figures

	Page
Figure 1. The Spectrum of Operations	2
Figure 2. The Army Transformation Campaign Plan.....	3
Figure 3. Organizational Structure of the IBCT	5
Figure 4. Organizational Structure of the Brigade Support Battalion (BSB).....	6
Figure 5. Organizational Structure of the HDC.....	7
Figure 6. Personnel and Equipment for the Ammunition Transfer Point.....	8
Figure 7. Current Army Munitions Distribution Doctrine.....	17
Figure 8. Possible IBCT Communications Network	20
Figure 9. The Heavy Expandable Mobility Tactical Truck.....	21
Figure 10. Containerized Roll-in/Roll-out Platform (CROP) with a Configured Load (CL).....	21
Figure 11. ATP Model Boundaries.....	35
Figure 12. Received, Stored, and Issued Data for 30-Day Base Case Operation (Short Tons).....	55
Figure 13. Throughput vs. Delivered Data for 30-Day Operation (Short tons)	56
Figure 14. Throughput vs. Delivered Data for 30-Day Operation (# of CROPs)	57
Figure 15. Picture of ATP Experiment.....	58
Figure 16. Design Matrix for the factorial design	59
Figure 17. Mean Throughput (Stons)	60
Figure 18. ANOVA Results for Average Throughput as Response Variable	61
Figure 19. Average Throughput Main Effects LS Means Plots	62
Figure 20. Average Throughput Interaction Effects LS Means Plot.....	63

Figure 21. Mean Short Tons Delivered	64
Figure 22. ANOVA Results for Average Average Short Tons Delivered as the Response Variable	65
Figure 23. Average Short Tons Delivered Main Effects LS Means Plots.....	65
Figure 24. Average Order to Ship Times Interaction Effects LS Means Plots.....	66
Figure 25. Mean Maximum CROPs Stored.....	67
Figure 26. Time Weighted Average Number of CROPs Stored	67
Figure 27. ANOVA Results for Maximum CROPs Stored.....	68
Figure 28. Average Maximum Short Tons Stored Main Effects LS Means Plots	69
Figure 29. Average Maximum CROPs Stored Interaction Effects LS Means Plot.....	70
Figure 30. Scatterplot Matrix for the Performance Variables	70

List of Tables

	Page
Table 1. General Assumptions for the ATP Model.....	38
Table 2. Assumptions for Arrival Process for base case model.....	41
Table 3. Assumptions for the ATP Operation for base case model.....	43
Table 4. Assumptions for Delivery Process for base case model	45
Table 5. Assumptions for the demand generation sub-model for base case model	47
Table 6. Assumptions for the retrograde sub-model for base case model	49
Table 7. Sources of Variance and Random Number Streams Assigned	50
Table 8. Performance Measures of Interest for Base Case ATP model.....	53
Table 9. Factors and Levels.....	58

Abstract

The high frequency and wide range of contingency operations during the last decade has sharply increased the significance of military responsiveness. The Army of the future will need to be able to quickly respond to a full spectrum of conflict—from stability and support operations to major theater wars. Today, military leaders have limited options when reacting to the wide range of current threats existing in our world. The nation needs ground combat units that can deploy very rapidly to stabilize a hostile area while possessing combat capabilities able to terminate a threat if necessary. The Army's answer to this requirement is the Interim Brigade Combat Team (IBCT).

Logistically supporting the IBCT will require the Army to leverage new technologies to automate supply activities, enhance communications, and minimize the intra-theater logistics footprint. The Brigade Support Battalion (BSB) is designed to provide distribution-based, combat service support to the IBCT leveraging many of the newest technologies available. One of the important missions of the BSB is to establish an ammunition transfer point (ATP) for the storage and distribution of ammunition stocks to all customer units throughout the IBCT area. This study employs an Arena 5.0 discrete-event simulation model to explore the capabilities of the IBCT ammunition transfer point to determine if the system will perform as predicted—to be capable of meeting a daily throughput level of 138 short tons of ammunition in support of the IBCT. Imposing realistic battlefield variance on the modeled system, a statistical analysis is performed to reveal significant factors influencing ATP system performance.

INTERIM BRIGADE COMBAT TEAM (IBCT)

MUNITIONS DISTRIBUTION STUDY

I. Introduction

The Post Cold-War Environment

The environment in which our military fights has dramatically changed over the last decade. Following the Persian Gulf War and the fall of the Soviet Union in the early 1990s, the probability of large-scale conventional war has severely diminished. In the last ten years, the U.S. military has responded to many types of operations including peacekeeping, peace enforcement, and humanitarian relief. These operations, called stability and support operations (SASO) aim to help calm uneasy regions throughout the world and are a part of what is called the full spectrum of operations. Figure 1 depicts this array of possible actions ranging from domestic disaster relief to nuclear war (U.S. Army Transformation Brief, 2000: 4). Considering this “full spectrum” of operations, the military faces a range of dynamic security threats throughout the world. To combat these threats, a need exists for a force able to quickly deploy with an extensive array of resources capable of deterring threats to achieve outcomes supporting strategic objectives.

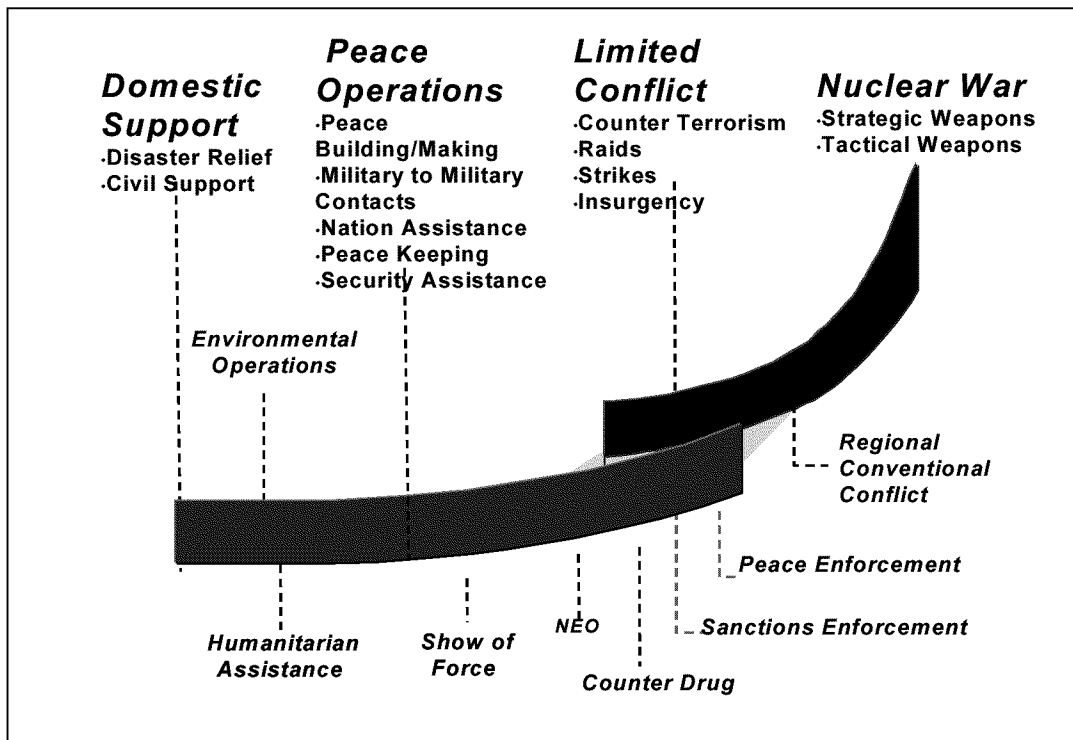

Figure 1. The Spectrum of Operations

The Army's Transformation and Revolution

To transform the Army from its current cold-war configuration into the full-spectrum capable military of the future, the Army has developed and begun executing the Army Transformation Campaign Plan (ATCP). The plan, which is to be implemented in three phases, intends to meet the Army Chief of Staff's vision for the land force of the future. Depicted in Figure 2, the ATCP began with the Initial Force in fiscal year 2000, continues with the Interim Force projected for activation in fiscal year 2003, and culminates with the Objective Force in 2010 (U.S. Army Transformation Brief, 2000: 5). The Initial Force consists of two initial Brigade Combat Teams organized at Fort Lewis,

Washington. These units are to be equipped with off-the-shelf and borrowed equipment during their initial development. The Interim Force is a transitional force that will consist of Interim Brigade Combat Teams (IBCTs), Force XXI units, and the remaining Army forces. The Objective Force represents the completely transformed Army to include the initial, interim and legacy units throughout the Army. The Objective Force will be able to deploy and sustain a Brigade Combat Team anywhere in the world in less than 96 hours, a division in 120 hours, and five divisions anywhere within 30 days. Leveraging new technologies to facilitate the projection of military force is one of the important aspects of the Objective Force.

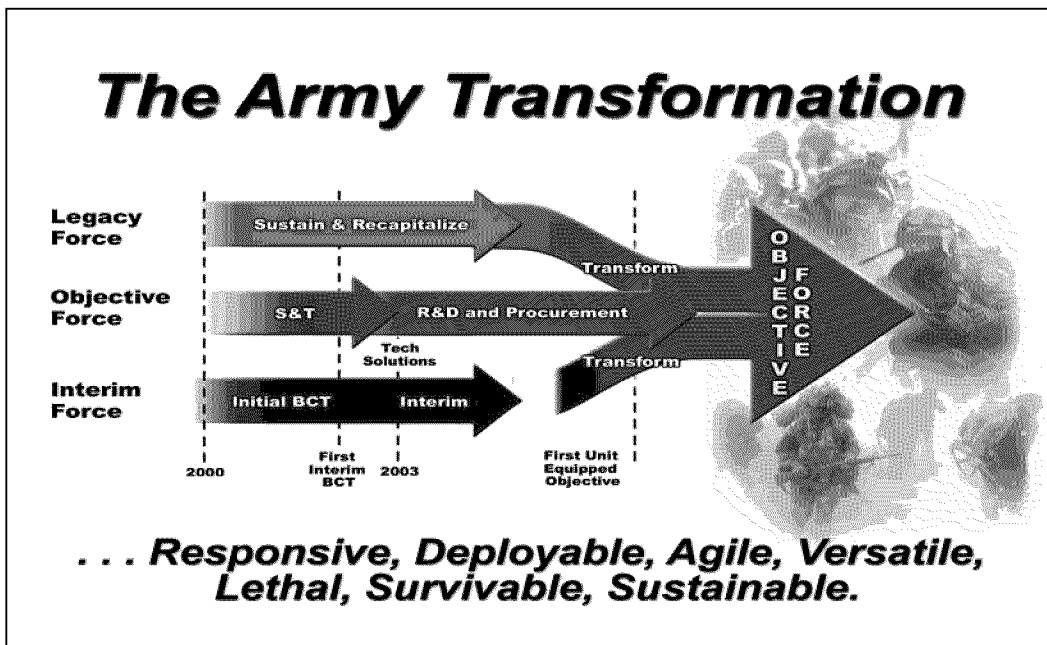

Figure 2. The Army Transformation Campaign Plan

To achieve this vision, a dramatic change in the Army’s ability to respond and operate is clearly necessary. This change is referred to as the Revolution on Military Affairs (RMA). The RMA seeks to utilize new technologies stemming from the dawn of

the Information Age to provide future military leaders visibility, maneuverability, and situational awareness never experienced on any battlefield in history. These new technologies illuminate the location, disposition, and condition of friendly forces, enemy forces, and the support infrastructure for each. Furthermore, these new technologies provide the future Army with reliable and accurate weapon systems to “effectively prosecute war with near-perfect economy of force, applying the right systems to the right targets at the right time” (Payne, 1999:1).

To deploy and sustain the future ground force and compliment the RMA, the Revolution in Military Logistics (RML) makes the most of new technologies to automate support activities, improve communications, and minimize the logistics footprint.

According to former Army Chief of Staff, General Dennis Reimer,

There will be no revolution in military affairs without first having a revolution in military logistics. We are dramatically transforming the way we support our forces. The revolution in military logistics is about rethinking logistics functions and processes that will enable decisive victories well into the future. This revolution spans the depth and breadth of military logistics by integrating logistics functions, replacing volume with velocity, reducing demand, and lightening the load on the ultimate customer—the warfighter. (Reimer, 1999: 2)

Essentially the military equivalent to what many commercial firms have done to remain competitive in today’s global market, the RML makes the most of new technologies to automate service and support operations, improve communications, and reduce dependency on stockpiles of inventory.

The Interim Brigade Combat Team

The Army of the future will be known as a capabilities-based force able to quickly deploy and respond to a full spectrum of conflict—from stability and support operations

to major theater wars. Today, leaders have limited options when reacting to the wide range of current threats existing in our world. Light forces are responsive, but lack lethality and staying power; heavy forces possess dominating combat power, but require too much time to deploy with current airlift capacities. The Army’s response to this demand gap is the interim brigade combat team (IBCT). As discussed in the prior section, the IBCT represents the second step toward the Objective Force. Figure 3 depicts the current structure of the IBCT. The IBCT basically fills the “medium size” gap between light forces and the heavy forces and is equipped to improve strategic responsiveness with enough firepower to resolve small-scale crises swiftly.

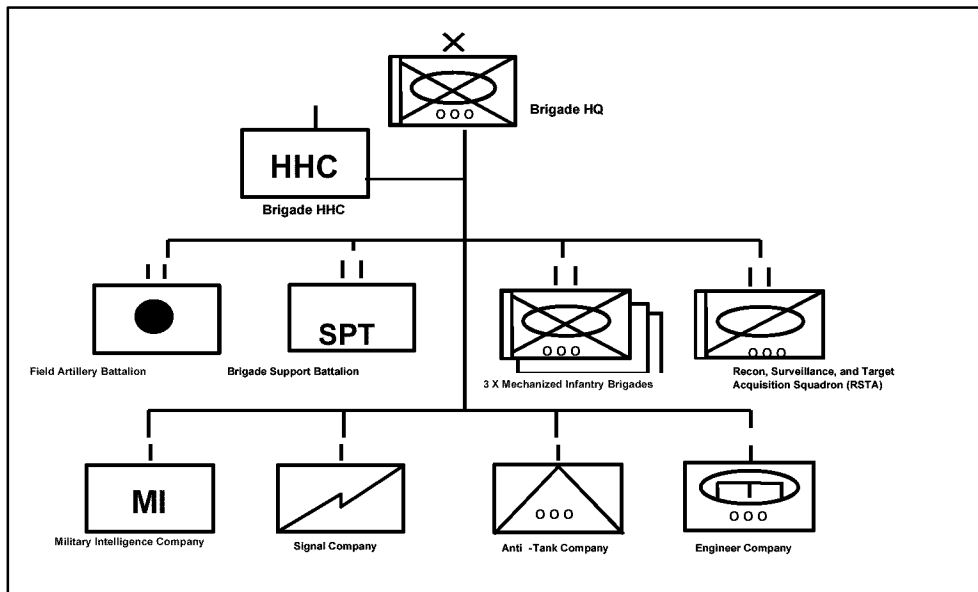

Figure 3. Organizational Structure of the IBCT

Organized as a mounted infantry unit, the IBCT is made up of three combined arms infantry battalions, various combat support units including a field artillery battalion, and one combat service support unit called the Brigade Support Battalion (BSB). As the

only combat service support (CSS) unit organic to the IBCT, the BSB is solely responsible for all CSS functions for the brigade. The BSB is comprised of three functional companies: the headquarters and distribution company, the brigade support company, and the brigade support medical company. Figure 4 illustrates the current makeup of the BSB. Each company in the BSB performs combat service support functions in accordance with RML concepts combining information dominance and

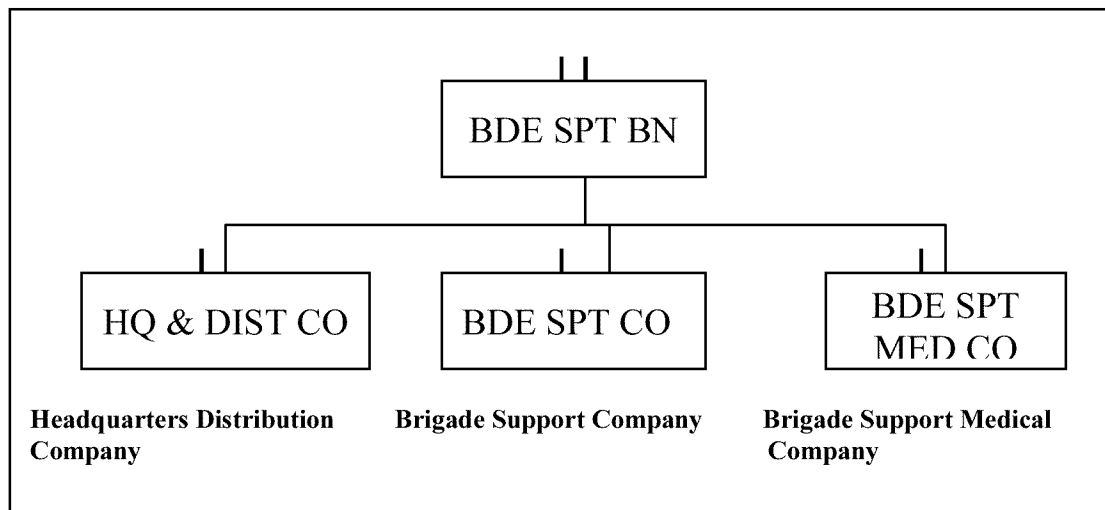

Figure 4. Organizational Structure of the Brigade Support Battalion (BSB)

modern support concepts combining information dominance and modern support assets to produce a more agile logistics system. Compared to traditional logistics units, the BSB is smaller in size but is highly dependent upon communication linkages for situational awareness and highly trained leaders for effective support to the brigade combat team. Supporting RML tenets, the size of the BSB reduces the theater’s logistics footprint adopting the notion that velocity compensates for less mass. The BSB utilizes distribution-based logistics management to “maximize and prioritize the throughput of forces, supplies, and sustainment material from the port of debarkation to the warfighting unit” (Witt, 1999: 41). This new approach to logistics reduces storage capacities

throughout the battlefield and increases dependency on the distribution system for on-time supply deliveries.

Scope of Research

This study will focus on ammunition handling and distribution to the IBCT. The headquarters and distribution company (HDC) of the BSB is assigned the responsibility of providing munitions support to the IBCT. Figure 5 displays the organizational structure of the company. Outfitted with limited personnel, material handling equipment, and truck assets, the Supply Support Platoon of the HDC is responsible for establishing and operating the ammunition transfer point (ATP) for the brigade combat team. Twelve soldiers equipped with two 10,000-pound Atlas forklifts and three Heavy Expanded Mobile Tactical Trucks-Load Handling System (HEMTT-LHS) operate the ATP section. The mission of the ATP section is to provide 100 percent of the IBCT's ammunition to

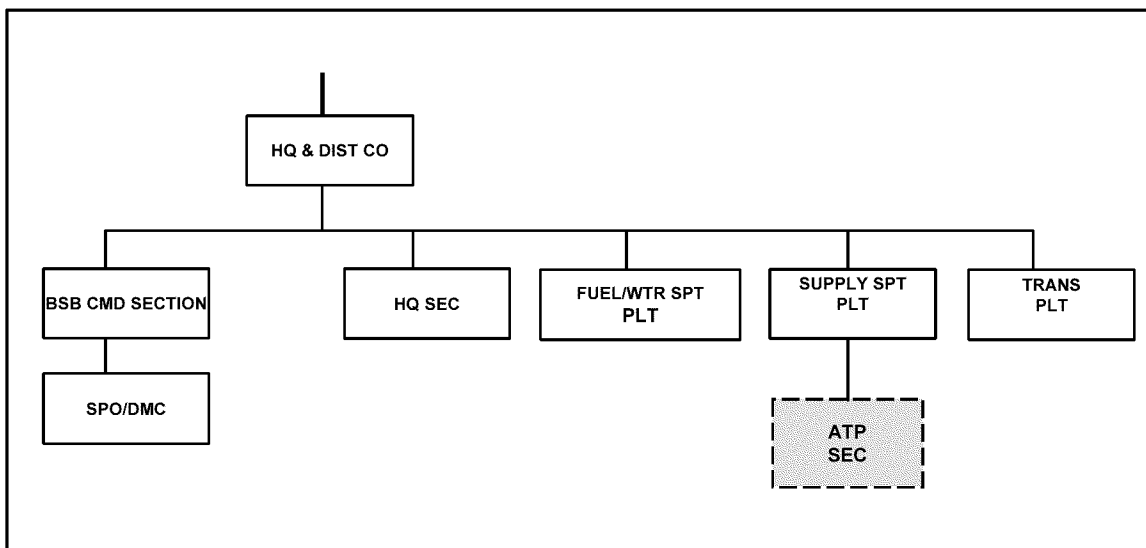

Figure 5. Organizational Structure of the HDC

infantry, armor, artillery, other combat support, and combat service support units organic to the brigade. Figure 6 depicts the make-up of the ATP's equipment. The ammunition transfer point is responsible for receiving munitions in unit-configured loads (UCLs) from corps or host nation support transportation assets. Once received, the ammunition is inspected, segregated, accounted for, secured, and prepared for distribution to the brigade. Transportation assets, HEMTT-LHS, from the HDC's transportation platoon

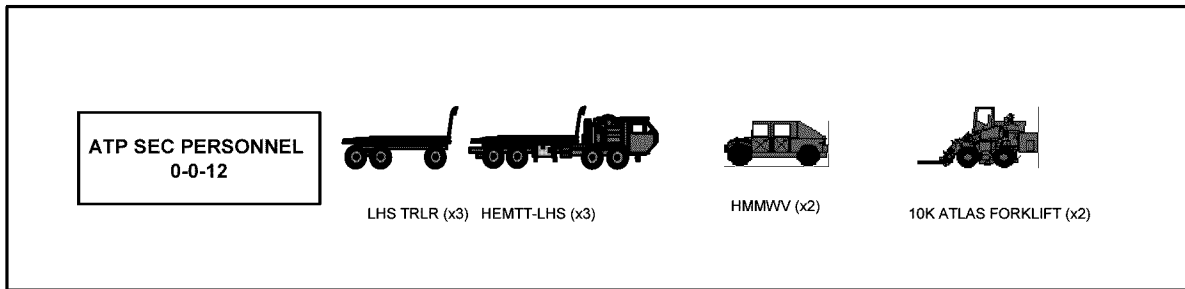

Figure 6. Personnel and Equipment for the Ammunition Transfer Point

provide transportation support to various customer unit locations within the IBCT. The ATP is an ammunition distribution node with limited storage and limited ability to reconfigure ammunition loads. According to combat developers working with the ammunition distribution to the IBCT, the ATP is projected to handle up to 138 short tons per day operating the transfer point within the brigade support area (BSA) (Ellison and Hale, 2001). The ATP acts mainly as a trans-load point, conveniently located to facilitate rapid transfer to distribution assets and ultimately to customer units.

Problem Statement

This study explores the capabilities of the IBCT ammunition transfer point (ATP) to determine if the system will perform as predicted—to be capable of meeting a daily throughput requirement of 138 short tons of ammunition in support of the IBCT. Model

development will consider initial entry conditions for an array of Support and Sustainment Operations (SASO) scenarios. Real-world battlefield variance, such as ammunition retrograde, manning and equipment degradation, and distribution variance will be imposed upon the model to reveal significant factors associated with the ATP system throughput.

Research Objective

The task of developing combat service support organizations from their infancy is one of the responsibilities of the Department of Combat Development for Combat Service Support (DCD-CSS) at the Combined Arms Support Command (CASCOM), Fort Lee, Virginia. Current DCD-CSS business practices associated with unit development lack quantitative based tools like simulation to aid in the analysis of unit capabilities and resource capacities. The objective of this research is to develop a computer simulation using commercial software to model and analyze the receipt, storage, and distribution of munitions to supported units in the IBCT. The model and its output analysis will provide the DCD-CSS with improved insight into the capabilities of computer simulation and aid in the development of combat service support activities for future Army organizations.

Outline of Thesis

The remaining chapters of this thesis cover a literature review, methodology, experimental design and analysis, and conclusions. The literature review chapter provides more background on logistics support of the IBCT and munitions management and handling processes employed by ATP personnel. Past research efforts focusing on

supply activities using automated decision support tools such as spreadsheets and discrete event simulations are also examined.

The methodology chapter describes the construction of the model in Arena 5.0 and begins by describing the ammunition transfer point in detail. The process for problem formulation, assumption development, and data input is then discussed. The model development process discussion follows to include validation and embellishments for realism.

Chapter 4, the design of experiments and analysis chapter, presents the statistical experiments conducted and the results of the analysis. Chapter 5 reviews the important results of the study and presents recommendations for further research.

II. Literature Review

Introduction

The purpose of this chapter is to provide a review of literature relevant to this research effort. The Interim Brigade Combat Team concept is still in its developmental stages; as a result, much of the research relies upon briefing slides, interviews of subject matter experts, and drafts of U.S. Army Field Manuals. The literature review begins with a look at simulation modeling with Arena and its application to supply chain management problems. Two ongoing studies using spreadsheet analysis and discrete event simulation are presented to demonstrate the use of these tools in improving military supply operations. A doctrinal review of the IBCCT's concept of support and the emerging configured load concept is presented as a critical concept toward ensuring the effectiveness of the ATP and distribution-based logistics. The chapter concludes with a discussion of the primary metric for this study—throughput. The concept of throughput is examined using Eliyahu M. Goldratt's Theory of Constraints philosophies.

Simulation of Supply Chains

Operations Research techniques have been applied to supply chain management problems since the 1960s. Three approaches to these types of analysis include continuous time differential equation models, discrete time difference equation models, and discrete event simulation models. In their journal article, "Modeling the dynamics of supply chains", Riddalls, Bennett, and Tip review and evaluate these methods measuring the ability of each to expose the dynamics of the supply system considered.

Their analysis finds that differential equations and difference equations models take an aggregate look at the supply chain and therefore lose the ability to consider individual entities within the supply chain. Both techniques can be used to solve flow rate problems for less complex systems but cannot be used to determine lot sizing or solve job-sequencing problems. Other limits with these methods are the absence of system delays and the inability to deal with the stochastic nature of demand and supply chain variance in general.

The deficiencies of the differential and difference equation methods encouraged the emergence of discrete event simulation models. These models emulate material progressing through operations and supply buffers adjusting attributes to denote the status of supplies. These types of models are also able to address supply chain phenomena such as queue reneging and balking, system breakdown lengths and inter-arrival times, and other stochastic factors associated with supply operations. Overall, the authors conclude that while differential and difference equations techniques are useful for solving local, less complex problems, the true behavior of the supply chain can best be assessed using discrete event simulation (Riddalls and others, 2000: 4).

Supply chain management has become one of the key factors for firms in achieving and retaining competitive advantage. Evaluating velocity and costs associated with supply chains has traditionally been done using deterministic problem solving techniques such as linear and integer programming and spreadsheet analysis. Wyland, Buxton, and Fuqua expose the emergence of simulation as a tool for analyzing supply chain systems in their article presented in January 2000's *IIE Solutions* magazine. Proponents of simulation modeling, the authors point out the inabilities of deterministic

tools to “evaluate variability in demand, supply time, and transit time” (Wyland and others, 2000: 37) and the strengths of discrete event simulation as applied to supply chain problems.

The greatest strength of simulation modeling is the ability to address and measure system variance and interdependence. Commonly used in manufacturing operations, simulation has grown in popularity in many industries to help solve a variety of problems associated with non-production activities. “Using simulation, firms are able to create a model of their supply chain system and test various levels of input that can emulate real-life inconsistencies” (Wyland and others, 2000: 40). To imitate system realism, many variants are incorporated into models including customer demand, processing times, distribution times, resource failures, and storage capacities. The level of variability built into the model depends on the intent of the study. Model detail is a function of study focus, which must be determined prior to commencing system analysis. The authors conclude the article with a discussion on the future of simulation projects associated with supply chain problems.

The growth in this area is tremendous. Supply chain firms are beginning to realize the power of simulation as a tool for system prediction and continuous improvement. Simulation consulting firms are experiencing huge growth in supply chain analysis work. The demand for simulation modeling applied to supply chain management will continue to build driven by competition and the pursuit for supply chain excellence.

Arena Simulation Software

This study utilizes Arena 5.0 Standard Edition Simulation Software for the development and analysis of the ATP model. Arena 5.0 is used by more than 6,000 firms throughout the world and is one of the premier commercial off-the-shelf simulation software packages available. Many organizations are using simulation with Arena to assist with high-level business decisions and process improvement initiatives. The Department of Defense and many Fortune 500 companies like Dow Chemical, Hershey, United Parcel Service, International Business Machines, Ford Motor Corporation, and General Motors all have used Arena successfully for various modeling projects (Rockwell Automation, 2000: 4).

To facilitate the development and analysis of the ATP model, the Arena 5.0 software package includes many essential tools. For model input analysis, Arena's Input Analyzer assists in determining appropriate statistical distributions for more accurate model processes such as load inspection times and transsload times. Arena's Basic Process, Advanced Process, and Advanced Transfer modeling templates facilitate the development of realistic receipt, storage, and distributing procedures for the ATP model. Arena's flowchart animation capability supports validation and verification efforts by allowing the analyst to visualize the process flow of the system being modeled. To aid in communicating system behavior to senior decision makers, Arena provides the capability to develop detailed animation of the system. Finally, upon completion of an accurate model, Arena's Output Analyzer helps to statistically compare results from sample iterations for final analysis and conclusions. Many of Arena's analysis and building tools

are used to develop and analyze the ATP model in this study. These tools are discussed in chapters three and four.

Military Application of Simulations

The transformation process now taking place within the U.S. Army motivates the application of modeling tools to evaluate proposed systems involving all aspects of combat service support operations. As discussed earlier, the revolution in military logistics aims to modernize current support methods and systems to enhance supply velocity and increase the agility of future support organizations. Simulation models allow the analyst to study the behavior of such systems for possible implementation. If the system is simple enough, traditional deterministic tools such as linear programming or queuing theory may be employed to evaluate the system. However, most systems modeled are complicated by statistical fluctuations—this is where simulation comes in. Pegden, Shannon, and Sadowski address the advantages of modeling using discrete event simulation. “Applying modeling techniques like simulation allow the analyst to test new operating procedures, decision rules, organizational structures, and communication flow without disrupting ongoing operations” (Pegden, C.E. and others, 1995: 9). The effect of proposed systems can be tested without allocating capital for costly purchases.

In concert with current doctrine modernization programs, military staff organizations throughout the Department of Defense are developing models to analyze current and proposed battlefield supply chain operations from depots to ports to supply operations delivering direct to combat units. Two of these efforts include CASCOM’s Container/Materials Handling Equipment Study (CMHE Study) directed by Major James

C. Phelps III (Phelps: 2001) and the United States Army Tank-Automotive and Armaments Command, Advanced Systems Concept Office, Logistics Research and Development Activity's In-Theater Modeling of Class V Logistics developed by Mr. Alan Santucci (Santucci: 2001).

The purpose of CASCOM's CMHE Study is to aid in the development of future combat service support organizations by providing combat developers an improved method for determining material handling equipment requirements given throughput capabilities, site layout details, and other environmental factors. Emerging doctrine focusing on distribution-based logistics motivated the study. Distribution-based logistics "maximizes and prioritizes the throughput of forces, supplies, and sustainment material from the port of debarkation to the warfighting unit" (Witt, 1999: 41). This new approach to logistics reduces supply capacities throughout the battlefield and increases dependency on material handling and transportation systems. The tool developed as a result of the effort is called the CMHE Assessment Tool or CAT. The CAT evaluates current material handling fleet levels and identifies potential shortfalls in capacities.

The study looked into several significant support organizations including the Headquarters and Distribution Company of the IBCT. The study found that the HDC's MHE capacity was adequate for all distribution needs including ammunition. The time and distance factors used for that analysis are used in this study for ATP layout distances and equipment speeds. The model developed from this study can be used to validate the CAT's findings for future ATP operations.

The U.S. Army Tank-Automotive & Armaments Command Logistics Research and Development Activity's model of ammunition logistics replicates an ammunition

corps storage area (CSA) to determine the throughput capability of the CSA. Created by Mr. Alan Santucci in Arena version 5.0, the model considers all aspects of CSA operations including: receiving, storage, issuing, retrograde, and shipping. Figure 7 illustrates the Army's current doctrinal ammunition supply chain and the location of the CSA. Note the link between the CSA and the ATP and that this templates current doctrine and not the future battlefield layout for the IBCT. An interesting aspect of the CSA model is the detail associated with the types of ammunition flowing through the supply node. The base model tracks eight separate types of rounds; later versions plan to include up to 500 types for further model realism. All assigned assets—MHE, vehicles, and personnel required to operate a CSA are included in the model. The model also uses

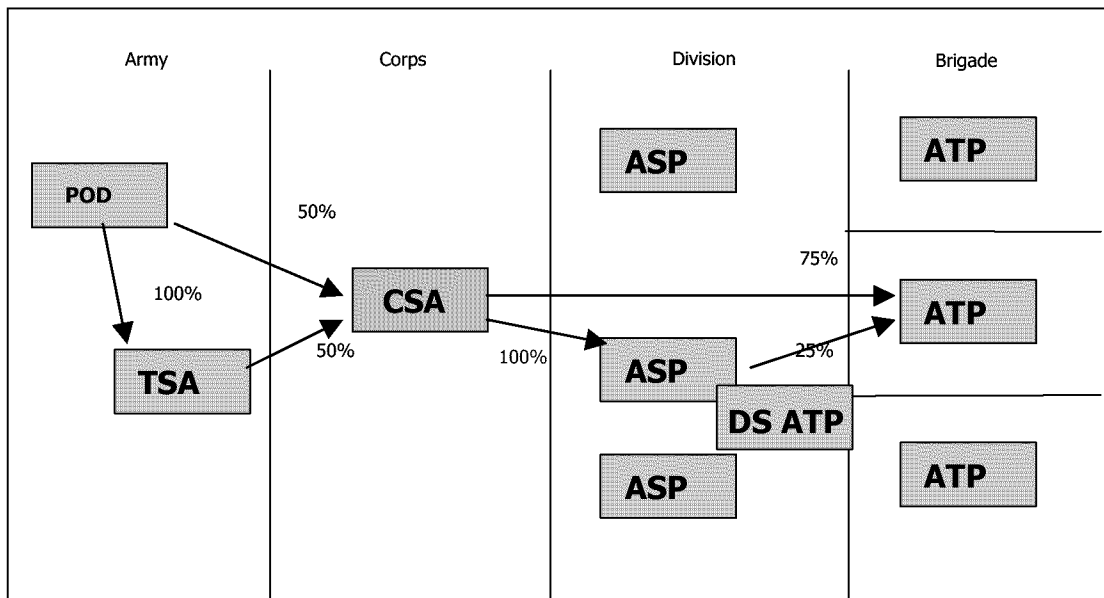

Figure 7. Current Army Munitions Distribution Doctrine

doctrinal distances for equipment movements throughout the storage area. Further model development aims to expand further down the ammunition supply chain to include area

storage points within the battlespace and employ more accurate forecasting models for customer unit consumption rates.

Both of these studies work towards improving the support capability of future war fighting units like the IBCT. Support for the IBCT is unique and challenging, but simulation modeling of future systems can assist in the development of units and increase the understanding of new systems and procedures ensuring successful implementation of emerging support concepts.

Supporting the IBCT

A fundamental concept of support for the IBCT is that information and velocity can replace stockpiles in the supply chain. Under this concept, the Army's ability to leverage emerging technologies is critical. With accurate information on customer unit sustainment conditions, total visibility of inventories, and a responsive distribution infrastructure, supplies can be received and delivered to the right place at the right time in the right quantity. To meet the challenges of keeping pace, the support community must employ enhanced procedures, high-tech resources, and robust information systems to ensure accurate situational awareness of the battlespace. The battlespace for the IBCT is dynamic and may expand or contract depending upon the situation. The proposed IBCT battlespace can range from a 50-kilometer by 50-kilometer square area up to a 100-kilometer by 100-kilometer square area. Supporting a large battlespace, the small CSS package is tailored for mobility and velocity and ultimately reduces the theater's logistics footprint.

Upon initial entry, the IBCT can sustain itself for 72-hours with “ready to fight” supplies available upon arrival at the aerial port of debarkation (APOD). These stocks, called unit basic loads (UBL), include all classes of supplies essential for mission accomplishment. The UBL is vital for initial entry operations regardless of the enemy situation. Subsequent sustainment operations will rely upon established links to all available sources of support. The establishment and use of these links are called CSS reach operations. These links include logistics depots, pre-positioned stocks, host nation support, civilian contracted firms, joint forces, and multinational coalition forces. To support the IBCT, these links are utilized to the fullest extent possible. Mission configured sustainment stocks from depot-level supply activities in the continental United States will be planned for and used during the initial sustainment phase of an IBCT deployment. Pre-positioned stocks may also be located in a staging area or some other location accessible to the brigade. These strategic stocks could require airlift capacity but can provide initial resupply support to the IBCT until the theater’s logistics infrastructure is established.

Once established, the CSS system focuses on customer demands communicated through information systems. Resupply operations will occur as needed—not daily like the traditional push support concept currently used by the Army. This system of resupply relies heavily on communications linkages exchanging information electronically throughout the battlespace. Figure 8 depicts a possible network supporting IBCT operations within an area of operation. Distribution to IBCT customers will be triggered only as necessary.

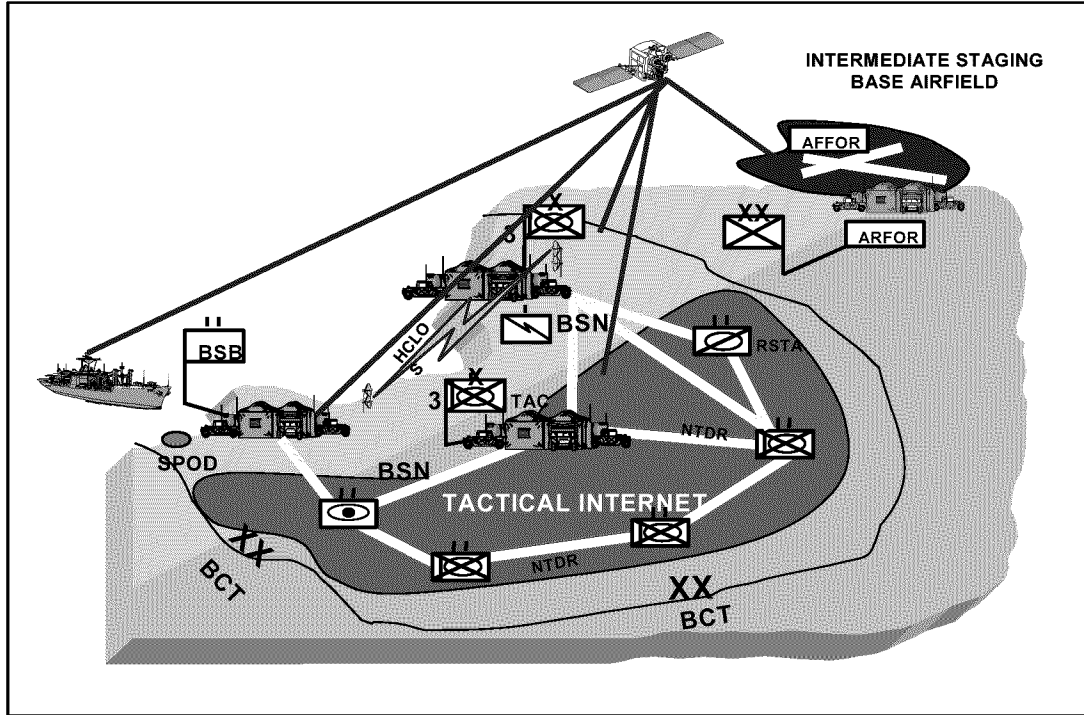

Figure 8. Possible IBCT Communications Network

Combat Service Support Enablers

To effectively execute deliveries, support units will operate state-of-the-art CSS resources in accordance with emerging velocity-focused concepts to enhance supply operations throughout the battlefield. These “CSS enablers” include the Heavy Expandable Mobility Tactical Truck (HEMTT) with Load Handling System (LHS) as pictured in Figure 9, the Containerized Roll-in/Roll-out Platforms (CROP) pictured in Figure 10, and the configured load (CL) also pictured in Figure 10. The HEMTT-LHS is the primary transportation asset for the IBCT. Performing like a common garbage truck, the HEMTT-LHS is able to automatically load and unload cargo-carrying platforms. The CROP is a cargo-carrying platform that is able to roll into and out of containers and

facilitates the aerial shipment of ammunition into theater. By reducing the need for material handling equipment, both systems are “cornerstone to sustainment supply velocity in the distribution pipeline for future Army CSS doctrine” (FM 4-93, 2000: A-3).



Figure 9. The Heavy Expandable Mobility Tactical Truck with Load Handling System (HEMTT-LHS)



Figure 10. Containerized Roll-in/Roll-out Platform (CROP) with a Configured Load (CL)

To make the most of these resource innovations, the Army is examining a concept that institutionalizes the use of configured loads (CL) for all sustainment deliveries. The CL concept aims to minimize the logistics requirement for storage and handling within

the forward areas of the battlefield and rely on configuration taking place back in the Continental United States (CONUS) at ammunition depots or manufacturing plants. “A configured load is defined as a preplanned load of supplies built to an anticipated or actual need, intended for maximum throughput and delivery to user units” (Dimensions International, Inc; 2001: ii). The loads can be built for specific missions—called Mission Configured Loads (MCL), or they can be built for a specific unit—called Unit Configured Loads (UCL). Building *accurate* loads for specific units or missions will greatly benefit IBCT concepts such as distribution-based and velocity-focused logistics and also removes the need for logistics personnel to break down bulk deliveries and prepare loads for distribution to the customer. According to a recent technical report on the institutionalization of configured loads prepared by Dimensions International, Inc. for the United States Army Logistics Integration Agency, the implementation of configured loads is “the best approach for the Army to achieve future CSS support goals” (Dimensions International, Inc.; i). These support goals include maximizing throughput and minimizing in-transit handling. The CL report strongly recommended that the Army work vigorously to implement the CL concept for all types of supplies and to further introduce the concept to all services within the Department of Defense. Supporting the IBCT will require innovative leaders able to manage resources in a dynamic environment. The keys to this support concept will be situational understanding, robust communications, distribution-based enablers, and the ability to make use of nontraditional support from multiple sources. Sustainment requirements will be dictated by the contingency; therefore, the BSB must be able to execute timely support for the array of possible missions throughout the battlespace. Of all the commodities managed

throughout the area of operations, ammunition influences the outcome of military engagements like no other. The following section addresses operation of the ammunition transfer point within this dynamic setting.

The Ammunition Transfer Point Introduced

As the focus of the study, an introduction to the ATP is presented. Located within the Brigade Support Area (BSA), the ammunition transfer point (ATP) serves as a temporary distribution point for all ammunition destined for the brigade (refer to Figure 6 for the location of the ATP). Ammunition is delivered to the ATP from the aerial port of debarkation (APOD) using host nation, contracted, or U. S. Army transportation assets. Having already been working under the configured load concept, the ammunition support system should ship all ammunition to the ATP in unit-configured loads (UCLs) on flatracks or CROPs to ensure timely deliveries to customers throughout the brigade. Responsible for munitions management for the IBCT, the Brigade Ammunition Officer (BAO) provides instruction to ATP personnel regarding all loads. As directed, the ATP section utilizes organic equipment to transport loads to temporary storage within the ATP and prepare loads for delivery to supported units. The Headquarters and Distribution Company's transportation platoon is responsible for transporting all classes of supply to units throughout the brigade area. Three organic HEMTT-LHS assets assigned to the ATP are used to operate the ATP and, when instructed, to relocate the ATP in accordance with the BSB Commander's plan.

Effective management of the ATP requires accurate accounting for ammunition received, stored, and issued to and from the transfer point. Leveraging technology for

improved accountability and visibility of stocks, the IBC T ammunition management team utilizes an information system designed for munitions visibility and communications. The Standard Army Ammunition System-Modernized (SAAS-MOD) “gives commanders and munitions managers a measurable capability for producing accurate and timely ammunition reports during all types of operations on a highly mobile battlefield” (FM 4-93; A-3). The use of SAAS-MOD begins with communications from the ATP. When the IBC T deploys independently, inventory data is transmitted via tactical communications links by ATP personnel to the BAO upon receipt or issue of a load. Using the automated system, the BAO retains visibility of stocks at the ATP, receives stockage level updates from the customer units within the brigade, and transmits sustainment requirements to higher ammunitions managers within or outside the theater. The BAO is responsible for notifying the ATP of pending missions or inbound deliveries. Information sent to the ATP consists of types and amounts of UCLs to prep for delivery or storage.

In addition to receiving, storing, and preparing UCLs for delivery, ATP personnel are also responsible for retrograde operations that require inspection, re-configuration if necessary, and load preparation for re-issue. With all activities considered, the ATP is designed to receive, store, and issue a maximum of 138 STONs of ammunition per day based on the combat developers estimates. A discussion of the ATP continues in Chapter three of this thesis.

Defining Throughput

One of the important measurements for Ammunition Transfer Point performance is what logisticians refer to as “throughput.” As one of the primary metrics for determining system effectiveness for this study, it is important that throughput is discussed and properly defined. After several interviews with subject matter experts during the model development process, it has become clear that the term throughput has different meanings to different people. “A measurement not clearly defined is worse than useless” (Goldratt, 1990: 60). Confusing and irrelevant measurements can hamper goal attainment and thus impede productivity. Metrics used to measure organizational success should be clearly understood and must also be purpose-related. A purpose-related, clearly defined and communicated metric will ultimately drive the organization toward goal attainment.

Throughput is defined differently for different organizations. For example, an emergency medical operation may define its throughput as the number of patients cared for per day. Academic institutions may measure throughput as the number of students graduated each year. Production firms may look to the number of widgets sold each year as their primary measure of organizational success. To properly define throughput for an organization, one must look to the purpose of the firm. It is this purpose that will drive the definition of throughput for the organization.

In the book, *The Goal—A Process of Ongoing Improvement*, Goldratt presents Jonah, a production consultant, who explains the for-profit definition of throughput as “the rate at which the system generates money through sales” (Goldratt, 1994: 60). The for-profit firm’s purpose is to make money, not to store finished goods, but to actually

sell the product or service provided. In *The Haystack Syndrome*, Goldratt goes on to explain, “most production managers think that if they have produced something, it deserves to be called throughput” (Goldratt, 1990: 19). Actually, if the firm produces something and does not sell it, it should not be considered throughput, but finished goods inventory waiting for demand. For not-for-profit organizations throughput is defined differently.

Although the not-for-profit organization’s goals are vastly different from the for-profit firm, Goldratt’s theories are still applicable. Although not formalized in the current theory of constraints literature, the not-for-profit firm can still apply constraints management theories for goal attainment. Theorists and practitioners have developed not-for-profit analogues to the classical for-profit definition of throughput. For example, as a result of five years experience in the Air Force Material Command depot environment, Major Stephen Swartz, an experienced graduate of the Goldratt Institute’s “Jonah” and “Jonah’s Jonah” Courses, explains that the not-for-profit organization must be focused on its goal or purpose and that throughput for these organizations is measured as “the rate of goal attainment” (Swartz, 2001).

The ATP section is considered a not-for-profit organization with a specific purpose. In order to establish a working measure of throughput for the ATP, it is necessary to determine its purpose. Current doctrine states that the ATP’s purpose is to receive, store, and issue ammunition for all units within the IBCT. Are all three functions actually the purpose of the ATP? Receiving ammunition to the ATP does not represent the purpose; neither does storage. Although receipt and storage activities are critical and very necessary for goal attainment, the ultimate purpose of the ATP is to

issue ammunition to customer units throughout the IBCT battlespace. Receiving and storage activities support the ATP in its primary goal attainment, but do not represent the goal of the organization.

The ultimate purpose of the munitions supply chain is to provide ammunition to the warfighter at the right place at the right time to ensure unit effectiveness at all times. The ATP represents the final supply node in the munitions chain and is therefore measured by its ability to fulfill demands from IBCT units. With this in mind, performance measures for our study will consider the traditional definition of throughput for the ATP and the Theory of Constraints (TOC) definition of throughput as simply the amount of ammunition delivered from the ATP to the customer. Chapter four presents both metrics for analysis within the Arena model.

Summary

This chapter described methods for modeling supply chains using various quantitative methods and the ongoing studies associated with inter-theater ammunition distribution. The Arena simulation software package used for this study was also introduced to set the stage for model development discussions. The main purpose of the literature review was to aid in the development of a realistic simulation model of the ATP. A discussion of the concept of support for the IBCT, the associated CSS enablers critical to sustainment operations, and the general mission of the ATP were presented to introduce critical concepts associated with ammunition handling and distribution. Finally, an in-depth discussion on throughput was presented to provide a clear understanding of throughput as one of the primary metrics for the ATP model study. The

next chapter of this thesis explains the methodology followed to develop the ATP model to ensure the reader is afforded a clear understanding of the model.

III. Methodology

Introduction

The purpose of this chapter is to present the process taken in the development of the ATP simulation model. Throughout the model development process, the steps for building a sound simulation model as presented in the first chapter of Averill M. Law and W. David Kelton's *Simulation Modeling and Analysis* (Third Edition) were followed to ensure proper modeling concepts were carried out (Law and Kelton, 2001: 83). The chapter opens with a more detailed discussion of the real-world ATP system. The information presented was used to determine which aspects of the ATP actually needed to be included in the simulation model. Once the level of model detail necessary for the analysis is determined, model development continues with problem formulation and model purpose. A detailed discussion of the conceptual model used to develop the simulation is then covered to include model boundaries, assumptions, logic, and input data.

The System of Interest—The Ammunition Transfer Point

To gain a better understanding of the IBCT's ATP and the many processes involved with its daily operations, several subject matter experts were consulted on several occasions. In addition, the Interim Brigade Combat Team Organizational and Operational Concept (IBCT O&O) and the latest Army Field Manual covering support for the IBCT, FM 4-93.7 were also used as references during the model formulation process.

Located within the Brigade Support Area (BSA), the ammunition transfer point serves as a temporary distribution point for all ammunition destined for the brigade. Assuming the BSA has moved away from the APOD area, ammunition must be delivered to the ATP from the APOD or SPOD using host nation support or U.S. Army transportation assets. In accordance with velocity-focused support doctrine, the ammunition support system, which originates in the continental United States and continues to the theater ports, delivers ammunition to the ATP in unit-configured loads (UCLs) assembled on CROPs. The UCL concept facilitates movement to and handling at the ATP and ensures timely delivery to customers throughout the brigade. With the unit-configured load concept in mind during the design of this organization, the ATP section's capability to reconfigure ammunition loads is limited; therefore, accurate UCLs from upstream supply nodes are essential for optimal support to the IBCT.

To effectively support the IBCT, the ATP will require a higher echelon level of combat service support for the transporting of ammunition to the BSB. Two types of transportation assets are generally used to deliver ammunition CROPs to the ATP—host nation commercial assets or U.S. Army assets like the HEMTT-LHS. During initial entry operations within friendly environments with treaty support, logistics planners may be able to exploit regionally available commercial support (RACS) transportation assets. These host nation assets can provide initial distribution from the APOD to the BSB until additional U.S. support assets can be brought into theater. It is assumed that host nation trucks are capable of handling only one CROP per trip to the ATP. To facilitate CROP delivery procedures, each host nation delivered CROP should be “positioned on the host nation truck with the A-frame oriented to the rear of the bed” (IBCT O&O, 2000).

Depending on the situation, the IBCT may depend on host nation transportation assets to deliver ammunition CROPs to the ATP for the initial days of an operation until U.S. assets arrive.

Different receipt procedures are used depending upon the type of truck delivering CROPs to the ATP. When host nation support assets are delivered to the ATP, the ATP section utilizes the organic HEMTT-LHS equipment to transport loads to temporary storage within the ATP. If U.S. assets are used to transport configured loads to the ATP, these assets are used to transport loads to temporary storage within the ATP. Both of these procedures greatly limit the use of forklifts and other organic material handling equipment for the operation of the ATP.

Upon receipt of the UCLs, ATP personnel inspect and inventory loads. Once inspected, the configured loads on CROPs are then temporarily stored in the ATP in anticipation of demands from the brigade customers. Equipped with fourteen HEMTT-LHS trucks for all classes of supply, the Headquarters and Distribution Company's Transportation Platoon is responsible for transporting all classes of supply to units throughout the brigade area. The ATP relies on this fleet for the distribution of all ammunition to customer units throughout the brigade area. These 14 trucks are used for all commodities, not just ammunition, so the amount of truck capacity available for ammunition delivery will fluctuate depending upon the situation. For the purposes of the ATP model, it is assumed that only four trucks will be available for ammunition deliveries to the customers.

Effective management of the ATP requires accurate accounting for ammunition received, stored, and issued to and from the transfer point. Leveraging technology for

improved accountability and visibility of stocks, the IBCT ammunition management team utilizes an information system designed for munitions visibility and communications. Responsible for munitions management for the IBCT, the Brigade Ammunition Officer (BAO) receives requests for ammunition from customer units throughout the brigade and in-turn provides instructions to ATP personnel regarding future deliveries for all customers. To complete this important task, the BAO uses the Standard Army Ammunition System-Modernized (SAAS-MOD). SAAS-MOD “gives commanders and munitions managers a measurable capability for producing accurate and timely ammunition reports during all types of operations on a highly mobile battlefield” (FM 4-93.7; 3-54). The use of SAAS-MOD begins with communications from the ATP. When the IBCT deploys independently, inventory data is transmitted via tactical communications links by ATP personnel to the BAO upon receipt or issue of a load. Using the automated system, the BAO retains visibility of stocks at the ATP, receives stockage level updates from the customer units within the brigade, and transmits sustainment requirements to higher ammunitions managers within or outside the theater. The BAO is responsible for notifying the ATP of pending missions or inbound deliveries. Information sent to the ATP consists of types and amounts of UCLs to prep for delivery or storage.

In addition to receiving, storing, and preparing UCLs for delivery, ATP personnel are also responsible for accepting ammunition turn-ins from supported units. These retrograde operations require inspection, re-configuration if necessary, and load preparation for return to the next higher ammunition supply point.

Other considerations for ATP operations include site location, layout, security, and displacement. Displacements occur frequently; to ensure continuous support, the ATP conducts spilt-based operations during movements until full closure at the new site is achieved. ATP leaders consult with the BAO for site location and layout. In accordance with the BSB Commander's guidance, the ATP layout is dictated by the tactical situation. No standard layout is prescribed for the ATP section; however, the transfer point should be located near main supply routes (MSRs) to facilitate pick-up and delivery and be placed at least 180 meters from other unit areas. Security is critical and must be coordinated with the HDC commander and the BSB Operations Officer. To reduce the ATP signature, local terrain features are used for cover and concealment. Using information about the system and its processes, the study now turns to the model development for the ATP system.

Formulating the Problem

The original idea for this modeling effort evolved during a workshop for ammunition subject matter experts at Fort Lee, Virginia in May 2001. During the meeting, several discussions concerning ammunition distribution for the IBCT were presented. At one point during the discussion, one of the ammunition experts claimed that without a real-life ATP available for evaluation a "virtual ATP" was needed to measure the actual capabilities of the ATP under various conditions. Knowing the strengths of discrete-event simulation, the combat developers at CASCOM decided to build a simulation model of the IBCT's ammunition process. The model would provide a better understanding of the ATP operation and the critical factors associated with the

ATP's performance capabilities. This study carries out that vision by developing a simulation model to explore the capabilities of the current ammunition transfer point (ATP) table of organization and equipment (TO&E) and determine if it is capable of meeting daily throughput requirements to support the IBCT under initial entry conditions. Two primary questions are to be answered by this study. The first seeks to predict the daily throughput capabilities for the ATP. The second aims to reveal the significant factors that affect the performance of the ATP operation.

Performance Measures of Interest

In a simulation study there are usually several different performance measures of interest. The model for this study is specifically designed to measure throughput and other related metrics for the ATP system. The performance measures for the ATP model include the following: (1) Average ATP system throughput (more is better)—the amount of ammunition (STONs) received, stored, and issued on a daily basis; and (2) Average delivered (more is better)—the amount of ammunition (STONs) delivered to fill customer demands on a daily basis; (3) Average maximum number of CROPs stored in the ATP (less is better); and (4) Average number of CROPs stored at the ATP at any given time.

The Conceptual Model

A conceptual model is a simplified representation of the system to be modeled. Once the objectives and performance measures are determined for the study, the task of building a conceptual model is required to provide the analyst and stakeholders a frame of reference for continued model development. In the case of the ATP, the development

of the conceptual model required several meetings with subject matter experts familiar with an ATP's operations within an IBCT environment. Like all simulation models, this model is only an approximation of the actual system. The formulation of the conceptual model begins with the determination of model boundaries. The model boundaries for this study are depicted by the outside dotted line in Figure 11. One can see that the incoming configured loads in the form of CROPs trigger the ATP process as they arrive from the theater's ports. These CROPs arrive via ground transportation assets from the host nation or from available U.S. Army assets. The ATP is the focal point of our model. The resources within the ATP service the CROPs upon arrival. After the receipt, inspection, and accountability processes are complete, the CROPs are then stored to await customer

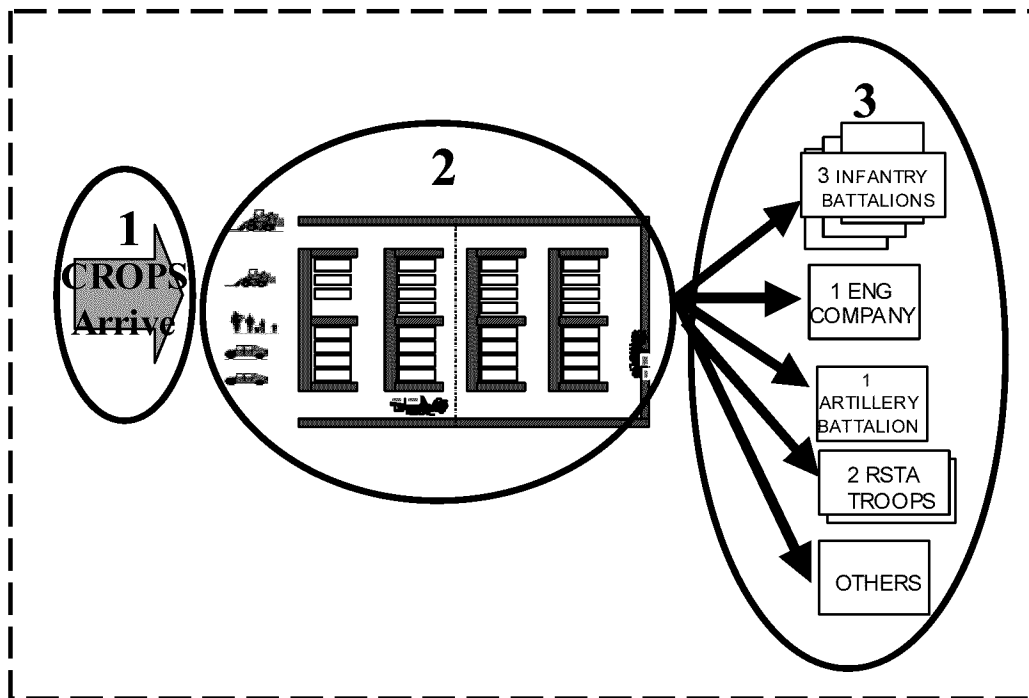

Figure 11. ATP Model Boundaries

demands. Once demand information is received for the specific types of configured loads, the CROPs are prepared for pick-up for the transportation platoon of the HDC. Although outside the boundaries of the ATP itself, notice that the boundaries of the model include customer deliveries. As discussed in chapter two of this report regarding the need to accurately measure true throughput for the system, the delivery process is included within the model and represents the final component of the conceptual model.

Looking at the ATP operation from a macro-perspective, one can see that there are three principle components of the system. The three components are circled and labeled in Figure 11. The first component is the CROP arrival process. The ammunition is delivered in the form of CROPs to the ATP. The second component is the ATP operation process. This part of the model includes all activities conducted within the ATP itself. The third component of the ATP system is the delivery process from the ATP storage areas to the eight customer units throughout the IBCT area.

The model also considers supporting logic created to emulate managerial functions and to impose realistic events onto the ATP operation. The supporting components essential for ATP operations include control logic to manage customer demand, logic to trigger data collection and output file creation, logic to control transportation assets available to transport CROPs within the ATP and from the ATP to customers, and logic to introduce ammunition returns on CROPs into the ATP system. The principle and supporting logic model components interact within the Arena model to create a more realistic and accurate model for analysis. The following section depicts the approach used to create the ATP model.

Model Development and Assumptions

This section describes the process and assumptions used to develop the ATP model. The discussion begins with the general approach and assumptions made to build the ATP model, and continues to describe each of the three principle model components—CROP arrival process, ATP Operation, and Delivery Process. The section concludes with a description of the supporting logic essential for model realism and accuracy. Each of the sections describes the thought process used to develop the particular model segment and lists any assumptions made. A table of applicable assumptions and key information associated with that section is provided for quick reference.

General Problem Framework.

Before beginning the model development process, a general framework was required for our baseline ATP model. Important features such as the timeframe of the operation, the duration of the operation, the type of operation, the external environment, and battlefield distances for the scenario were needed before the model could be created. Subject matter experts provided information for many of these general assumptions. The general dimensions for the ATP were taken from the CMHE Assessment Tool (CAT) input data set number 25 (Phelps, 2001). Battlefield distances were established using Vignette Six of an IBCT scenario-training packet developed by the United States Army Training and Doctrine Command (TRADOC) and used by CASCOM in their IBCT rock drill to develop the concept of support for the IBCT and subject matter expert input (Cattran, 2001). These conditions are listed in Table 1 along with the assumption related to each. The assumptions were made with a basic understanding of current IBCT

doctrine, a focus on the model purpose and performance metrics, and the understanding that the model must be as realistic as possible for valid analysis.

Table 1. General Assumptions for the ATP Model

GENERAL CONDITIONS	ASSUMPTIONS
Operation Timeframe	Initial Entry Operation
Size of Theater	Brigade only
Type of Operation	Support and Sustainment Operation (SASO)
Length of Operation under these conditions	30 Days
BSB Movements	None; For 30-day period all distances remain the same
Political Environment	Friendly “Treated Supported” environment with host nation support assets available for contraction.
Threat Level	Minimal; ATP personnel maintain minimal security during the period. NBC = Zero; All ATP personnel maintain a MOPP level zero posture during the period.
Equipment Readiness: Mean Miles Between Failures converted to Mean Time Between Failures; Mean Time to Repair	MTBF = EXPON (15840) min. ~ 11 days. MTTR = GAMMA (60,2) min. ~ 2 hours. (For ATP HEMTT-LHS and Transportation Platoon HEMTT-LHS systems)
Terrain and Infrastructure	Terrain does not seriously degrade support activities. Infrastructure able to provide functional APOD and capable road network.
Theater ports	Model addresses a generic aerial port 35 KM from the BSB. A seaport’s specific characteristics are not modeled.
Battlefield distances	See Appendix B
Number of Customers considered	<i>Total of 8:</i> Seven major customers (1 FA Battery, 3 INF Battalions, 2 RSTA Troops, and an ENG Company); with all others (OTHERS) grouped for the analysis.
Incoming CROPs from the APOD	All <i>incoming</i> CROPs from CONUS supply chain are assumed accurate.
Flatrack or CROP availability	No limit to Flatracks or CROPs available
Time units	Minutes
Distance units	Kilometers

Like most discrete-event simulation programming languages, Arena relies on entities to drive activities and events within the simulation model. In the ATP model there are two types of entities used. The first type is the *CROP entity*. These entities represent unit-configured loads built into CROPs for a specific type of unit (FA, INF, etc.). CROP entities are created to follow the arrival of an aircraft to the theater APOD. CROP entities are transported throughout the model using Arena's transporter constructs. These constructs allow the analyst to model many types of material-handling systems. In the case of the ATP model, all U.S. Army truck assets, and all host nation support trucks are modeled as transporters moving CROP entities from the ports through the ATP and to the customer units where the CROP entities are consumed to complete the distribution process.

The second type is the *logic entity*. Logic entities have no physical significance. Found in logic sub-models, these entities trigger events that change conditions of the ATP or collect information for analysis. Further discussion regarding logic entities can be found in the logic sub-model section of this chapter. The model description now continues with the following sections addressing each component of the model.

CROP Arrival Process.

The CROP arrival process depicts the actions associated with bringing unit configured CROPs into the theater via airlift and then delivering the CROPs to the ATP via ground transportation assets. In essence, this component of the model addresses the unloading of the aircraft, the staging of ammunition CROPs, and the delivery of CROPs to the ATP by appropriate trucking assets.

The process begins with the arrival of a United States Air Force C-17 cargo aircraft to the theater aerial port. While the actual aircraft arrival is not modeled explicitly, the CREATE node associated with aircraft arrivals takes into account the maximum capacity of eight CROPs on a C-17 cargo aircraft, initial arrival time for the first resupply shipment, and constant inter-arrival times over the 30-day period. Following their arrival, each CROP entity must be given two important characteristics or attributes—one for the type of truck used to deliver to the ATP and another for the type of CROP it is. To carry out these tasks, we use Arena’s DECIDE and ASSIGN nodes to partition and label the arriving CROPs in accordance with subject matter expert guidance. The DECIDE and ASSIGN combination assigns each entity with the appropriate weight and type of arriving CROP into the assigned attributes.

Two types of vehicles can bring CROPs to the ATP under the IBCT concept—host nation assets and U.S. Army truck assets from the combat service support company (CSSC). It is assumed that host nation support trucks are able to transport only one CROP per lift and that U.S. Army trucks are able to transport two CROPs per lift. The type of truck available is dependent on the operational situation. “In cases where significant contractor support is rapidly available, few elements of the CSSC may be required early on.” (FM 4-93.7, Annex A (63-7) (Coordinating Draft) 2001). For the purposes of the ATP model, we assume that host nation contract support is available for the initial ten days of the operation. The mission to deliver CROPs to the ATP is transferred to the CSSC on day eleven. Table 2 depicts all the assumptions and important facts associated with the CROP arrival process. The actual Arena model for the arrival process can be found in Appendix A of this report.

Table 2. Assumptions for Arrival Process for base case model

VARIABLE OR CONDITION	ASSUMPTION
Type of Aircraft delivering CROPs to the IBCT.	United States Air Force C-17. Estimated to be capable of delivering 8 CROPs.
Arrival time for initial resupply aircraft	3601 minutes (06:01 am on day 3)
Inter-Arrival times for follow-on resupply	1440 minutes (every 24 hours)
Percentage of Field Artillery CROPs	40%
Percentage of Infantry CROPs	24% (Divided equally into 3 Battalions)
Percentage of Engineer CROPs	12%
Percentage of RSTA CROPs	14% (Divided equally into 2 Troops)
Percentage of Other CROPs	10%
Weight of Field Artillery CROPs (Stons)	10.8
Weight of Infantry CROPs (Stons)	10.69
Weight of Engineer CROPs (Stons)	9.0
Weight of RSTA CROPs (Stons)	8.7
Weight of Other CROPs (Stons)	6.8
Capacity of Trucking assets (# of CROPs)	1 CROP for Host Nation; 2 CROPs for U.S. Army
Number of delivery trucks in each fleet	6 vehicles for Host Nation fleet; 6 vehicles for U.S. fleet = CSSC fleet
Type of Truck delivering to the ATP	Days 1-10 use host nation support trucks Days 11-30 use U.S. Army trucks

ATP Operation.

This component of the model describes the events associated with receiving unit configured CROPs at the ATP from each of the two delivery truck types and storing the CROPs by customer type. The ATP Operation models assigned personnel and equipment as they receive and store CROPs for future demands. Subject matter expert guidance and current doctrine were used to develop the ATP operation portion. The reader is referred to the “The System of Interest—The Ammunition Transfer Point” section of this chapter for a review of ATP activity as triggered by the arrival of CROPs to the ATP from the aerial port.

Regardless of the type of delivery vehicle arriving to the ATP, both vehicles and their loads are initially inspected for accountability processing and safety. Following inspection, the procedures for the two types of vehicles differ because of security precautions. Host nation support trucks are prohibited from entering the ATP; therefore, the CROP entity is transferred or cross-loaded from the host nation truck to an internal ATP HEMTT-LHS. From there, the host nation truck is excused to return to the APOD, while the ATP HEMTT transports the single CROP to its appropriate storage location within the ATP. U.S. Army truck assets carrying two CROPs are allowed to drive escorted by an ammunition handler into the CROP storage area and drop off each CROP at the designated storage locations.

Once in storage, the CROPs, regardless of how they arrived, remain in storage queues to await the arrival of a demand from customer units within the brigade. Upon receipt of a customer demand, CROP entities are released (first in—first out) from the storage queues into request for transporter queues. The release of the CROP to enter the request queue triggers Arena's transporter sequence. The transporter cycle includes the request for a transporter, the uploading of CROPs onto the transporter, and then the delivery of the CROP(s) to the customer using proper distances and speeds. Table 3 lists the assumptions and important information associated with the ATP Operation component of the model.

Table 3. Assumptions for the ATP Operation for base case model

VARIABLE OR PROCESS	ASSUMPTION
CROP Processing	
Host Nation delivery Inspection process	TRIA(15,20,30) min.
Trans-load process	TRIA(3.5,5,7) min.
SAAS-MOD paperwork processing time	UNIF(4,7) min.
U.S. Army delivery Inspection process	TRIA(20,30,45) min.
Delay to store two CROPs from U.S. Army	TRIA(5,9,14) min.
Storage	
Queue discipline	First in, First out (FIFO)
Storage Areas	Segregated into five customer types; unlimited capacity for CROPs for each customer
Resources	
Shifts	12 hours on – 12 hours off daily 1 st Shift: 0600 - 1800 2 nd Shift: 1800 - 0600
ATP personnel per shift	1 E6 Shift NCOIC; 1 E5 Supervisor 4 E1-E4 Ammunition Handlers (Total of 12 soldiers)
ATP 10K Rough Terrain Forklifts (2)	*Failures and Repairs: MTBF = EXPON (4,572)min. ~ 76.2 hr MTTR = GAMMA (16,3)min. ~ .79 hr * (Carabetta and Kern, 1998)
ATP HEMTT-LHS System (3)	All ATP LHS systems working properly; Trailers used sparingly within the ATP

Delivery Process.

This component of the model represents the actions associated with delivering unit configured CROPs from the ATP to each of the five customer types. Every attempt is made to incorporate a “typical distribution day” as described in the Interim Brigade Combat Team Organizational and Operational Concepts (IBCT O&O, 2000). The typical day for the model’s transporter section delivers to an array of different sized units from Battalion to Company and all customers do not receive deliveries everyday. Following the vignette scenario given, seven customers and an eighth “OTHERS” are considered for the analysis. Working within a 50km by 50km area, the delivery process begins with the

receipt of a demand from one of the customers and ends when the customer receives its CROP or CROPs as requested.

Following the receipt of demand and subsequent release of CROP entities from each storage queue, Arena's transporter sequence is triggered. To transport the CROP entities, the process begins with a "call" to the Transportation Platoon for a truck to transport the ammunition CROP. Recall that the Transportation Platoon is responsible for all commodity distribution; therefore, we assume that only *four* of the fourteen trucks will be available to the ATP for delivery to customers. No internal ATP material handling equipment is used to upload the trans platoon HEMTT-LHS. To upload CROPs onto the trans platoon HEMTT-LHS only one ATP soldier is necessary to supervise the load handling system process and ensure proper accountability. Trucks may pick-up one or two CROPs depending on the number of CROPs awaiting delivery on that day (the programming logic checks to see how many await delivery in each queue—see Appendix A). Each Transportation platoon HEMTT departs the ATP with the appropriate number of CROPs and delivers the CROP(s) without the customary protection of a huge convoy; however, the model assumes that the "BSB (will) normally provide its own security" (IBCT O&O, 2000). The enemy situation under a SASO mission may necessitate a security vehicle; however, the model does not explicitly model the forming and movement of an actual convoy launched from the ATP. The over-the-road delivery of CROP(s) to the customer uses a distance matrix within the expected 50km by 50km area of operation and an average speed randomly drawn from a distribution of appropriate speeds for the transporter. The distribution selected for long movements is the Uniform distribution bounded from 25 kilometers per hour to 40 kilometers per hour. This range

of speeds injects realism for movements by implicitly considering traffic congestion and other conditions along the routes that influence the pace of the transporters. The distance matrix and assigned speed for each transporter is used by Arena to calculate travel times between stations. Upon arrival to the customer area, the transporters simply drop the CROP load and look to see if there is any retrograde CROP needing a return back to the ATP. Retrograde CROPs for our model are actually CROPs with material needing to be returned to higher ammunition support units. If retrograde is present, the transporter picks-up the load for return to the ATP. If no retrograde is on hand, the transporter simply returns to the Transportation Platoon to receive further instructions. Road conditions are assumed approved for all size loads and clear of enemy personnel. Table 4 lists the assumptions and important information associated with the CROP delivery component of the model.

Table 4. Assumptions for Delivery Process for base case model

Variable or Condition	Assumption
Number of HEMTT-LHS available to the ATP for deliveries and retrograde returns	4; the other 10 trans platoon vehicles are occupied with other commodities
Equipment Readiness: Mean Miles Between Failures converted to Mean Time Between Failures; Mean Time to Repair	MTBF = EXPON (15840) min. ~ 11 days. MTTR = GAMMA (60,2) min. ~ 2 hours.
Loads	Loads may consist of one or two CROPs for the same customer.
Routes	Trucks with trailers <i>do not</i> deliver to two different customers; each delivery utilizes a two-way or “there and back” route
Distances	See Appendix B
Road network / infrastructure	Fully capable for routes necessary to reach all stations
Speeds	Over-the-road: UNIF (25,40) KM per hour; Within ATP areas: 5 KM per hour
Enemy Threat level along routes	Model assumes Brigade Support Battalion provides security for ammunition trucks depending on the enemy situation; no breakdown delays are experienced during movements.
Time to supervise load pick-up, establish convoy formation if needed, and fill-out any paperwork	TRIA (15, 19, 24) min.

Supporting Logic.

Logic routines or sub-models increase model realism by triggering events that emulate real-world actions that ultimately increase model validity. Logic sub-models can also be used to control certain aspects of the system being modeled. The ATP model uses five types of supporting logic routines to change environmental conditions of the ATP and trigger realistic events associated with ATP operations. These routines induce events on the system to inject battlefield realism or control the operational status of certain resources within the system. This section aims to describe the general purpose of the five support routine types included in the ATP model. The logic sub-models include demand generation and communication, APOD to ATP delivery truck availability, truck assets reliability, retrograde activities, and data collection routines. A table for the assumptions associated with each logic routine is provided for clarification. Appendix A of this report includes the actual coding for each sub-model.

The demand generation sub models behave like the Brigade Ammunition Officer (BAO) sending a message to the ATP instructing the personnel to prepare stored CROPs for the delivery process. To do this, a system was created to send information to the ATP to “open a gate” that allows CROPs to leave the storage areas after demand information is received. Each customer type has its own demand communication model that essentially informs the ATP that a demand is present and that a CROP or CROPs (if available) should be prepared for delivery. Without actual consumption rate data for time between demand requests and the amount of ammunition requested, several assumptions were made with guidance from subject matter experts.

For the base case ATP model, each of the seven customers modeled is assigned a time between requests (between 720 and 2,160 minutes) and an amount of ammunition requested (in number of CROPs). To develop these rates and times, we considered the IBCT delivery plan to deliver two days of supplies every other day. Without knowledge of the amounts of ammunition consumed by each customer, we assumed different number of CROPs for different customers with guidance from subject matter experts (Cattran, 2001). The base case model also considers levels of activity necessary to test the ability of the system and its resources. As such, the demand data used for the analysis well exceeds the current planned consumption levels for SASO missions. Table 5 lists the assumptions and important information associated with the demand communication sub-model.

Table 5. Assumptions for the demand generation sub-model for base case model

VARIABLE OR CONDITION	ASSUMPTION
FA Customers	
Demand communicated	At end of days two, three, and four. Subsequent demands within TRIA (720,1440,2160) minutes after.
Number of CROPs each demand request	2 CROPs for each demand
3 INF Battalion Customers	
First demand communicated	<i>1st Battalion:</i> At end of day two and subsequent demands within TRIA (720,1440,2160) minutes after. <i>2nd Battalion:</i> At end of day three and subsequent demands within TRIA (720,1440,2160) minutes after. <i>3rd Battalion:</i> At end of days two and three and subsequent demands within TRIA (720,1440,2160) minutes after.
Number of CROPs each demand request	<i>1st and 2nd Battalions:</i> 2 CROP per demand <i>3rd Battalion:</i> 1 CROP day two and 2 CROPs day three.
ENG Customers	
First demand communicated	At end of day one and day four. Subsequent demands within TRIA (720,1440,2160) minutes after.
Number of CROPs each demand request	1 CROPs on day one and day four.
2 RSTA Troop Customers	
First demand communicated	<i>1st Troop:</i> At end of days two and four subsequent demands within TRIA (720,1440,2160) minutes after. <i>2nd Troop:</i> At end of days two and four subsequent demands within TRIA (720,1440,2160) minutes after.
Number of CROPs each demand request	1 CROPs on day one and day four.
OTHER Customers	
First demand communicated	At end of days two, three, and four. Subsequent demands within TRIA (720,1440,2160) minutes after.
Number of CROPs each demand request	2 CROPs on day two and 1 CROP on days three and four.

The delivery asset control sub-model controls the type of trucks delivering to the ATP from the port. This simple routine changes the type of vehicle from host nation support trucks to U.S. Army truck assets and makes only one assumption. We assume that host nation support assets are contracted for deliveries from the aerial port to the ATP for the first ten days of the operation. On the eleventh day, U.S. assets become available for use and the host nation contracts are terminated. Table 2 lists the assumption for this sub-model. See Appendix A for the actual Arena model.

The truck assets reliability sub-model creates breakdown events and subsequent repair activities in accordance with accepted times between failures and repair times used by planners (Menard, 2001). For the ATP model, all downtime events focus on the Headquarters and Distribution Company transportation assets—the ATP HEMTT-LHS and the transportation platoon’s HEMTT-LHS fleet. Table 4 shows the mean time between failure and the mean time for repair information used in the reliability sub-models. These models are also shown in Appendix A.

The retrograde sub-model injects realism into the model by occupying ATP personnel with reconfiguration work from returned ammunition from the customers. An unfortunate reality in the ammunition community, retrograde CROPs are munitions sent back from customers for a number of reasons including excess, incorrect, suspended, or unfamiliar munitions. Regardless of the reason for return, retrograde work complicates ATP operations. For retrograde operations, the Brigade Ammunitions Officer (BAO) provides managerial guidance to ATP supervisors regarding the disposition of the retrograde stocks. For the purposes of the ATP model, it is assumed that all retrograde

ammunition is sent back to higher ammunition support echelons after inspection and minor reconfiguration is completed. Within the ATP model, retrograde CROPs are created from a generic customer and sent to the retrograde pick-up station to wait for a vehicle from the transportation platoon for return back to the ATP. Upon arrival at the ATP, the retrograde materials are inspected and then transported to the reconfiguration area. Two ammunition handlers and a forklift are then tasked to conduct minor reconfiguration of the CROP for transporting back to the next higher ammunition support activity in the theater. Once ready, the retrograde CROP enters a queue and awaits transport to the higher ammunition unit. Table 6 lists the assumptions for the retrograde sub model.

Table 6. Assumptions for the retrograde sub-model for base case model

VARIABLE OR PROCESS	ASSUMPTION
Retrograde CROPs	
1 st Retrograde CROP arrival	Start day seven (10,080) min.
Time between retrograde CROPs	Six days (5,760) min.
Retrograde Inspection (one inspector)	TRIA (5.0,7.5,12.0) min.
Retrograde Processing (two handlers)	TRIA (50,60,65) min.
10K Forklift	10K Forklift is used to sort ammunition during reconfiguration process.
Disposition of Retrograde CROPs	Reconfigured CROPs transported to next higher ammunition activity

Two data collection sub-models simply write measurement information gathered throughout the Arena model to an external file for analysis. The first data collection model collects daily receipt, store, issue, and delivered information and writes these results to a file in ASCII code. This data is then used to conduct statistical analysis of our model. The second data collection sub-model accumulates order-to-ship times for each

of the model's customers and then writes the information to a file for further analysis. Both of these data collection routines rely on strategically placed assign blocks throughout the model for appropriate data points. Further information regarding the data from these models is presented and discussed in chapter four. No assumptions are associated with the data collection sub-models. The models are also shown in Appendix A of this thesis.

Sources of Variation and Assigned Stream

The common random number variance reduction technique was used for all sources of variation within the model. This technique allows the analyst to eliminate variance-producing events associated with random number draws during the simulation. By incorporating this technique, we are in a better position to allow the actual system to influence the response and prevent lucky or unlucky random number draws. Table 7 displays the source of variance and its assigned random number stream.

Table 7. Sources of Variance and Random Number Streams Assigned

SOURCE OF VARIATION	STREAM VALUE
Time Between Failures: ATP LHS, Trans Assets, and Forklifts.	Stream 1
Time Between Demands: All demand draws.	Stream 2
All repairs to ATP LHS, Trans Assets, Forklifts.	Stream 3
Times for all Processes.	Stream 4
Times for all transport movements	Stream 5

Summary

This chapter discussed the process of creating the ATP model. The model development process began by understanding the system and understanding the problem to be answered. The development process then continued toward the establishment of the model boundaries and the details of ATP operations. As discussed in chapter three, after discussions with subject matter experts, we determined that the ATP model could be built and understood as three serial processes—the CROP reception process, the CROP storage and issue processes, and the CROP delivery process. To add realism to the model, logic sub-models were integrated into the model environment inducing realistic events to perturb the ATP system and generate realistic battlefield events. The many model parts act in concert to create a dynamic model of the ATP operation and all the variance associated with ammunition management for the IBCT.

We now can begin to analyze the system using design of experiment techniques to reveal critical factors of the system and their effects on the performance measures for ATP operations. Chapter four introduces the planned experiments for the ATP model and provides results from the analysis. Chapter five concludes the thesis providing recommendations from our analysis and recommending future study as a result of this work.

IV. Experimental Design, Results, and Analysis

Overview

This research began with the objective of developing a simulation model of the ammunition transfer point supporting the Army's new Interim Brigade Combat Team to predict the throughput capability of the system and to uncover significant factors influencing the system. To this point, our research has discussed the background associated with the transformation of the Army and the role of the IBCT within the transformation effort. Additional discussion focused on ammunition distribution and logistics support systems for the future Army. We introduced the benefits of discrete-event simulation and how it can assist a decision maker by predicting the performance of a system in response to organizational changes before actual costs are incurred. Chapter three addressed the model development process listing the assumptions and input parameters used to construct the "virtual ATP" we set out to create. The study now continues into its final phase using statistical analysis tools to predict the throughput capability of the ATP and determine the significant factors influencing ATP operations.

Performance Measures for the ATP

Several performance measures are used to study the ATP system for our analysis. These measurements are collected using Arena's ASSIGN blocks purposefully located to collect information at the appropriate times during the 30-day simulation replications. As seen in Appendix A, the data collection sub-models were created to automatically

tabulate and write the values of all performance measures to a file. Table 8 displays the list of all five performance measures used for the analysis with values created from the base case model. As a primary metric for system performance, our model measures

Table 8. Performance Measures of Interest for Base Case ATP model

Rep # (1 rep = 30 days)	Daily Average Throughput (Stons)	Daily Average Delivered (Stons)	Time Weighted Statistics for CROP Storage		
			Average CROPs Stored (Stons)	Average CROPs Stored (#)	Maximum CROPs Stored (#)
1	212.005	70.788	21.729	2.108	9
2	213.509	71.27	20.698	2.181	9
3	211.451	70.602	22.731	2.223	9
4	222.505	74.265	19.71	2.112	9
5	219.03	73.61	63.895	6.014	13
6	218.183	73.348	64.978	6.925	14
7	213.021	71.104	20.024	2.148	9
8	213.091	71.03	10.775	1.101	8
9	212.832	71.184	32.022	3.055	10
10	219.606	73.322	21.945	2.123	9
11	211.174	70.751	42.861	4.067	11
12	213.605	71.442	31.692	3.019	10
13	223.279	74.426	11.086	1.101	8
14	218.404	73.04	32.488	3.127	10
15	211.847	70.856	32.875	3.144	10
16	220.265	73.422	11.074	1.119	8
17	220.809	73.843	32.264	3.086	10
18	218.531	73.084	32.162	3.081	10
19	221.21	73.977	32.376	3.094	10
20	219.701	73.354	22.073	2.154	9
21	210.808	70.269	10.479	1.076	8
22	211.986	70.782	22.425	2.182	9
23	216.323	72.328	31.012	3.156	10
24	214.776	71.711	23.676	2.296	9
25	210.101	70.514	51.798	4.891	12
26	221.018	73.793	22.006	2.127	9
27	207.086	69.029	10.19	1.058	8
28	219.188	73.063	10.892	1.107	8
29	222.386	74.129	10.913	1.105	8
30	219.723	73.481	32.428	3.107	10
Averages	216.248	72.261	26.843	2.636	9.533

average system throughput in terms of short tons over the 30-day operation. In accordance with current ammunition doctrine, the throughput measure is calculated by averaging the sum of CROP weights received, stored, and issued over the 30-day operation. For comparison purposes, the average weight of CROPs delivered is also collected. Each metric is tabulated upon completion of the respective processes on a daily basis and then averaged for the 30-day simulation period.

Several other important measurements are used to provide information on system effectiveness. To retain appropriate mobility and manage the footprint of the ammunition transfer point, the ATP must minimize the number of CROPs stored while simultaneously preserving the ability to service customer needs quickly. As such, the amount of ammunition stored over time at the ATP is measured in average weight, average number of CROPs, and the maximum number of CROPs stored at any given time. These average calculations are collected using Arena's built-in time weighted average. As we will see in the experimental design section of this chapter, these performance measures serve as response variable values for each of the design points within our statistical experiments.

Base Case Model Results

We begin the analysis of our model by reporting the results of the base case scenario. The base case model, as described in detail in chapter three, was used to provide a base level for our analysis of the ATP system. Presented earlier in this chapter, Table 8 displays the results of the five key performance measures for the base case model scenario. According to current ammunition doctrine, the ATP was designed to handle a

maximum of 138 short tons per day. Observing the average throughput results in the first column of Table 8, we see that the base case ATP system easily exceeds the projected throughput for all replications. To see actual daily throughput numbers, a single 30-day base case replication is graphed in Figure 12 showing the amount of ammunition (in short tons) received, stored, and issued for the base case model. Looking at the graph, it is apparent that the first shipment is not received until day three. A system “warm-up” period of approximately five days is observed as CROPs initially enter the system for storage and issue. A “steady state” period is noticed from day six through day thirty. The graph may be deceiving because only stored stons can be seen after day five; however, the received and issued levels are depicted, just hidden by the stored stons series plot. We can infer from this graph that once operations reach a steady state phase,

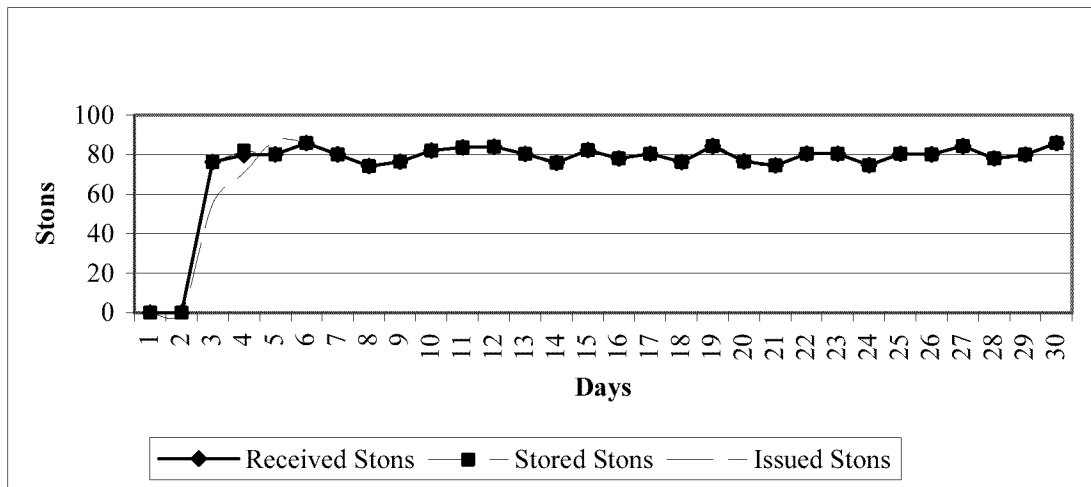

Figure 12. Received, Stored, and Issued Data for 30-Day Base Case Operation (Short Tons)

the ATP system is able to receive, store, and issue the entire batch of incoming CROPs within a 24-hour period. Recall, the base case model assumes one aircraft per day delivering eight ammunition CROPs per aircraft to a 24-hour ATP operation. The times

allotted for receipt, storage, and issue activities allow CROPs to be handled quickly upon arrival and issued as soon as a customer demand is recognized and a transportation platoon truck is available. Considering the high level of customer demand and transportation trucks available within the base case system, this result is feasible.

In chapter two, we introduced Eliyahu Goldratt’s concept of system throughput. There we discussed how receiving, storing, and issuing activities support the ATP in its goal attainment, but do not represent the primary goal of the organization. Recall our position that throughput should be defined as the total ammunition delivered to the customer. This global view of the ammunition supply chain within the brigade area differs greatly from the current measurement system. To see the difference, two graphs are created showing each measure. Figures 13 and 14 were created using the base case scenario output. Each graph reveals the steady state operation achieved after day five and the substantial gap between the two measurements. Note that the slight variations in the measurements shown in Figure 13 results from the different CROP weights. The graphs also point out that the current throughput definition gives inflated measurements for the ATP operation. As the final supply activity in the ammunition supply chain, the ATP

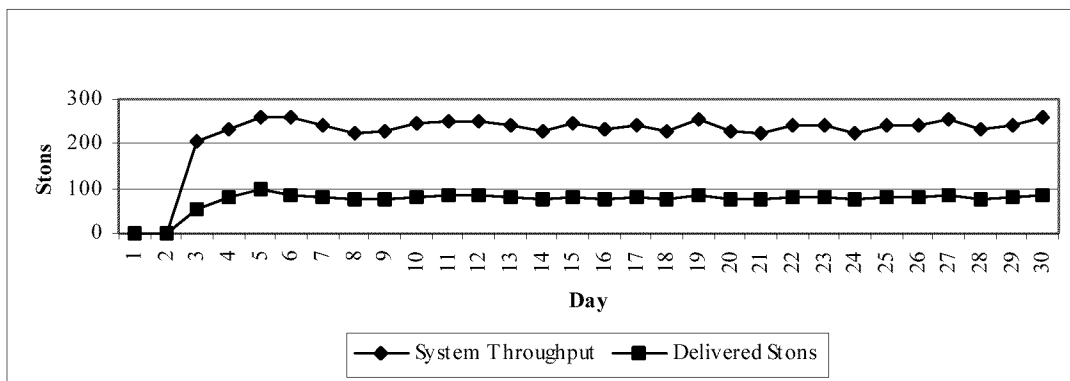

Figure 13. Throughput vs. Delivered Data for 30-Day Operation (Short tons)

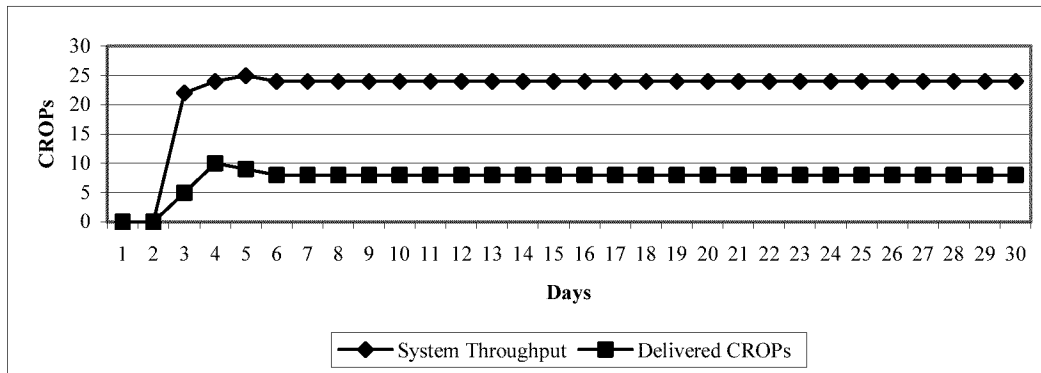

Figure 14. Throughput vs. Delivered Data for 30-Day Operation (# of CROPs)

performance measure should focus only on customer’s needs and the ability of the organization to fill those needs. This measurement concept requires a global look at the ammunition supply chain to include distribution. Mission accomplishment at the ATP will rely heavily on timely deliveries and thus must be considered when measuring system performance.

Experimental Design

The experimental design for a simulation study provides the analyst a guide for deciding which particular model configurations or design points to run so that the desired information can be achieved. The purpose of a statistical design of experiments in simulation is to maximize the information gained from the analysis while minimizing the cost of runs. For each experiment, the analyst must first determine the response variable of interest and then select the level of the decision variables or factors. Factors in simulation experiments are classified as controllable or uncontrollable, the determination depends on whether a system’s manager can manipulate the factor in the real world system of interest.

Our experiment will study three different responses by manipulating three controllable factors to measure the average performance of the ATP system and determine which factors significantly affect that performance. Factors are independent variables that can be studied using an ANOVA model. Table 9 lists the factors and their assigned levels for the planned experiment.

Table 9. Factors and Levels

FACTORS	LEVELS
Number of Shifts	1 – one shift 2 – two shifts
Number of Trans Platoon HEMTT-LHS vehicles	1 – one vehicles 2 – four vehicles
Number of ATP HEMTT-LHS vehicles	1 – one vehicles 2 – three vehicles

We will utilize SAS JMPin 4.0.2 (Academic) statistical software to build a three-factor, two-level, balanced design model and conduct a 2^3 factorial experiment. Figure 15 provides a symbolic view of the experiment planned. The factors are listed as inputs into the ATP model,

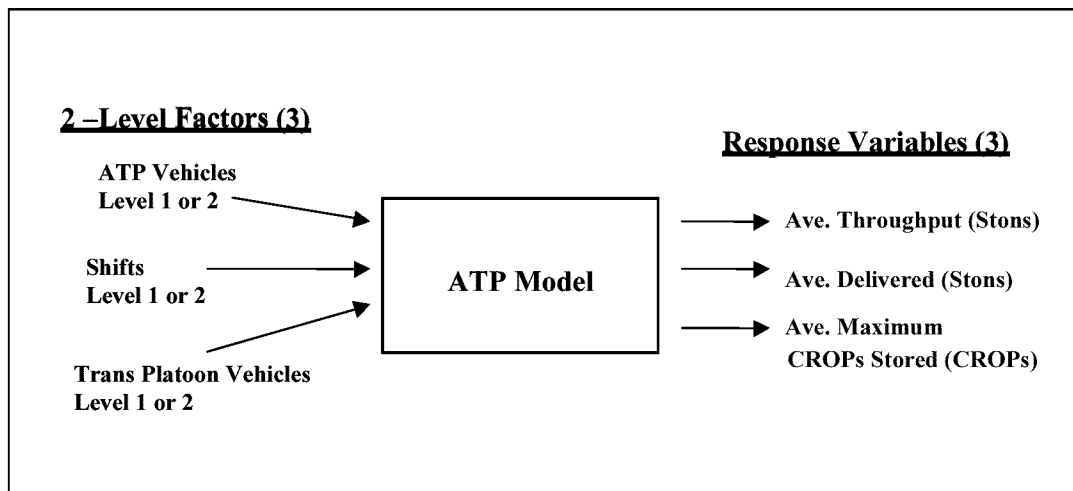

Figure 15. Picture of ATP Experiment

while the response variables of interest are depicted as outputs. For our analysis, we will use all three factors at two levels each and use three response variables of interest—Total Average Throughput, Total Average Delivered, and Average Maximum Number of CROPs Stored. Allowing JMP’s design of experiments macro to aid in the design sequence, Figure 16 shows the design matrix used for the 2^3 factorial.

DESIGN POINT	FACTOR 1: # OF SHIFTS	FACTOR 2: # OF TRANS VEHICLES	FACTOR 3: # OF ATP VEHICLES	RESPONSES 30 REPLICATIONS
1	1	1	1	R _{11...R₁₃₀}
2	1	1	2	R _{21...R₂₃₀}
3	1	2	1	R _{31...R₃₃₀}
4	1	2	2	R _{41...R₄₃₀}
5	1	1	1	R _{51...R₅₃₀}
6	2	1	2	R _{61...R₆₃₀}
7	2	2	1	R _{71...R₇₃₀}
8	2	2	2	R _{81...R₈₃₀}

Figure 16. Design Matrix for the factorial design

Analysis of Variance

“In multifactor studies, analysis of variance models are employed to determine whether the different factors interact, which factors are key, which factor combinations are “best”, and so on” (Neter and others, 1996: 670). We use the multifactor ANOVA to uncover system factors that influence ATP performance exposing the significance of *main* and *interaction* effects of independent variables or factors. A main effect is the direct effect of an independent variable on the response variable, while an interaction effect is the synergistic effect of two or more independent variables on the response variable. One of the important strengths of an ANOVA model is its ability to uncover and measure the impact of any interaction effects.

For our analysis, we consider the *null hypothesis* that says that there is no difference in average response as a result of the factors and interactions, and the *alternate hypothesis*, which proposes that there are some factors or interactions that do influence the average response. With three different response variables used, three ANOVAs were performed in JMP. The design point values displayed in each ANOVA table are the averages of 30 replications run at each design point.

Prior to discussing the results of our experiments, it is important to note that all ANOVA models were examined for appropriateness using residual analysis. Facilitated by JMP’s ability to create the necessary plots, residuals were checked for consistency of error variance, outliers, independence, and normality. Each model was examined to ensure no serious departures from these conditions were encountered using normal probability plots, residual sequence plots, and residual plots against the fitted values. Slight nonnormality was encountered for one of the tests; however, the departure was not extreme and it was decided to proceed with the analysis understanding the robustness of the ANOVA against departures of normality (Neter and others; 1996: 776).

The Results – Average Throughput as Response Variable

The first experiment discussed uses average system throughput as the response variable with all three factors at two levels. Results are taken from JMP using an alpha value of .05. Figure 17 shows the treatment means for all factor level combinations.

Number of Shifts		1		2	
Number of Trans Vehicles		1	2	1	2
Number of ATP Vehicles	1	196.87	214.97	214.30	217.73
	2	196.22	214.89	214.69	216.25

Figure 17. Mean Throughput (Stons)

Figure 18 displays the results of the ANOVA from JMP's output. Looking at the p-values provided, we see that two of the main effects (Shifts and Trans Vehicles) significantly ($p\text{-value} < 0.05$) change the level of throughput achieved at the ATP. In

Summary of Fit - Ave. Throughput Response					
RSquare			0.786814		
RSquare Adj			0.781324		
Root Mean Square Error			4.360149		
Mean of Response			210.7376		
Observations (or Sum Wgts)			240		

Analysis of Variance - Ave Throughput Response					
Source	DF	Sum of Squares	Mean Square	F Ratio	
Model	6	16348.272	2724.71	143.3237	
Error	233	4429.540	19.01	Prob > F	
C. Total	239	20777.813		<.0001	

Effect Tests - Average Throughput Response					
Source	Nparm	DF	Sum of Squares	F Ratic	Prob > F
# of shifts	1	1	6005.0411	315.8735	<.0001
# of Trans Veh	1	1	6539.3654	343.9797	<.0001
# of shifts*# of Trans Veh	1	1	3784.7601	199.0837	<.0001
# of ATP Veh	1	1	12.1356	0.6383	0.4251
# of shifts*# of ATP Veh	1	1	0.4474	0.0235	0.8782
# of Trans Veh*# of ATP Veh	1	1	6.5228	0.3431	0.5586

Figure 18. ANOVA Results for Average Throughput as Response Variable

addition, the interaction of Number of Shifts with Number of Trans Vehicles is significant. Using JMP's ability to provide Least Squared (LS) means plots, pictorial views of these effects are provided to help explain the significant effects.

Figure 19 shows a set of plots for each of the main effects. Notice the slopes of the lines within each plot. These slopes represent the intensity of the effect as its level changes between its assigned levels. The slopes associated with the number of Trans Vehicles and the number of Shifts illustrates their significance to the level of system throughput. In contrast, the slope associated with ATP Vehicles is zero. The flat slope

associated with the number of ATP Vehicles reveals its insignificance to system throughout. This phenomenon is most likely due to the abilities of the HEMTT-LHS vehicles used by the U.S. Transportation trucks when delivering to the ATP. Recall the

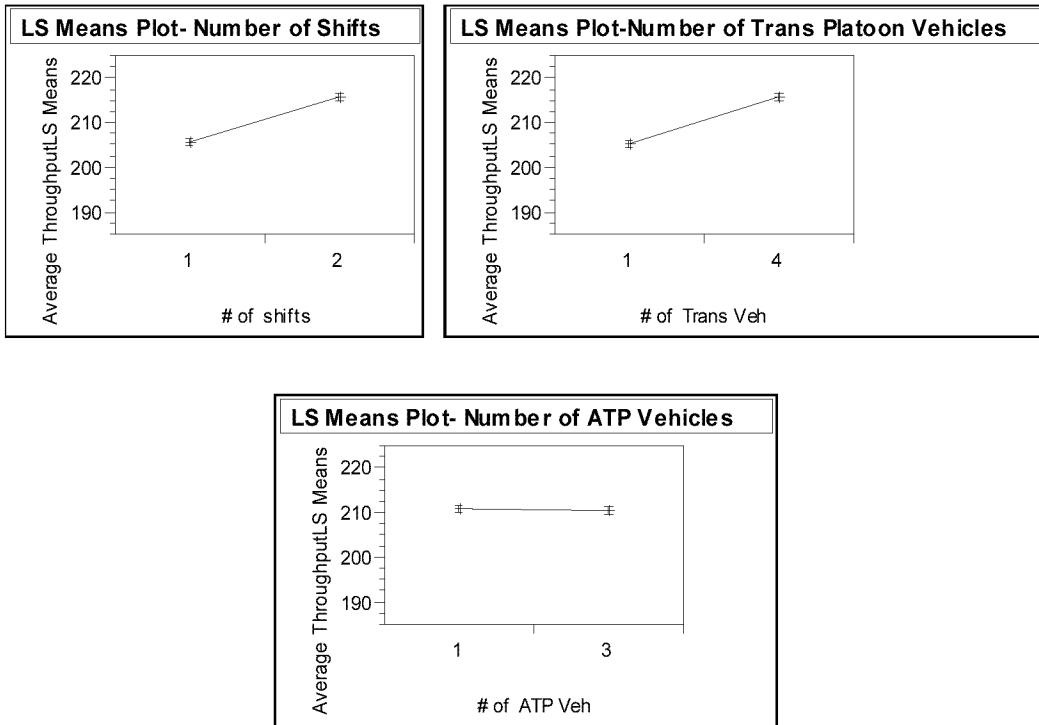

Figure 19. Average Throughput Main Effects LS Means Plots

U.S. delivery unit’s ability to enter the ATP and drop off CROPs into the storage areas without involving the ATP vehicles because of the HEMTT-LHS technology. If the host nation contract trucking company had delivered for the entire 30 days, we would expect this main effect to have a stronger influence on system throughput. The numbers of Shifts and the number of Trans Vehicles effects have an influence on the throughput of the system. If the ATP is operated with six soldiers within one shift the amount of throughput is negatively affected. Likewise, if only one Trans Platoon vehicle is available for delivering CROPs to customer units, a fall in throughput is expected due to

the lack of transportation platoon drivers to issue ammunition to. All three of these results make sense and provide positive feedback concerning the accuracy and validity of the ATP model itself.

The interaction effects supplied by JMP provide valuable information. Shown in Figure 20, interaction effects provide insight into our system when two factors combine to create a synergetic influence. Looking at the Shifts and Trans Vehicles interaction

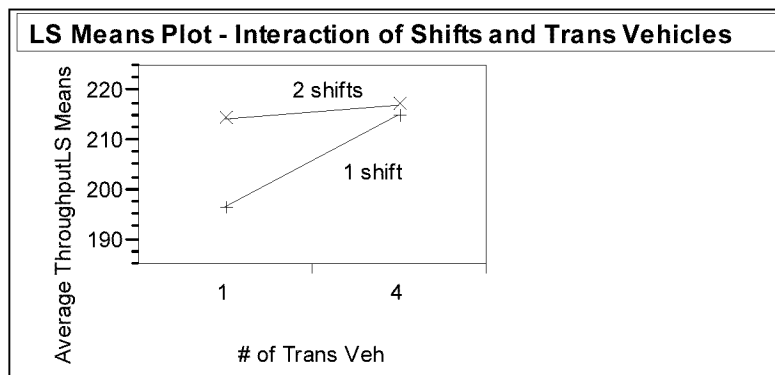

Figure 20. Average Throughput Interaction Effects LS Means Plot

plot, one can see that the number of Trans Vehicles significantly influences throughput if there is one shift working the ATP. With two shifts operating at the ATP, the lack of vehicles has much less effect on ATP throughput. A possible explanation is that if the ATP is open 24-hours a day with two shifts, and if we assume that the transportation platoon conducts night resupply deliveries, the constant deliveries from the lone truck are able to keep up with delivery requirements to customer units throughout the brigade area.

The Results – Average Short Tons Delivered as the Response Variable

The second experiment discussed uses the average short tons delivered as the response variable with all three factors at two levels. Results are also taken from JMP using an alpha value of .05. Figure 21 shows the treatment means for all factor level combinations.

Number of Shifts		1		2	
Number of Trans Vehicles		1	2	1	2
Number of ATP Vehicles	1	51.05	70.91	69.23	72.61
	2	50.85	70.78	69.59	72.26

Figure 21. Mean Short Tons Delivered

Figure 22 displays the results of the second ANOVA. Looking at the p-values provided, we see that, like the average throughput analysis, Shifts and Trans Vehicles significantly ($p\text{-value} < 0.05$) affect the average short tons delivered to customer units within the brigade area. In addition, one interaction also significantly affects this response. The interaction of Shifts and Trans Vehicles is significant. Using JMP's ability to provide Least Squared (LS) means plots, pictorial views of these effects are provided to help explain the significant effects. Figure 23 shows a set of plots for the three main effects. The results found for this experiment mirror those from the throughput experiment. Notice the slopes of the lines within each plot. Again we see the flat slope associated with the insignificant ATP Vehicles effect. The Shifts and Trans

Summary of Fit	
RSquare	0.969113
RSquare Adj	0.968318
Root Mean Square Error	1.577361
Mean of Response	65.91068
Observations (or Sum Wgts)	240

Analysis of Variance				
Source	DF	Sum of Squares	Mean Square	F Ratio
Model	6	18189.356	3031.56	1218.439
Error	233	579.720	2.49	Prob > F
C. Total	239	18769.076		<.0001

Effect Tests					
Source	Nparm	DF	Sum of Squares	F Ratio	Prob > F
# of shifts	1	1	6036.5856	2426.215	<.0001
# of Trans Veh	1	1	7879.9991	3167.117	<.0001
# of shifts*# of Trans Veh	1	1	4270.3454	1716.33	<.0001
# of ATP Veh	1	1	0.4001	0.1608	0.6888
# of shifts*# of ATP Veh	1	1	0.4355	0.1750	0.6761
# of Trans Veh*# of ATP Veh	1	1	1.5904	0.6392	0.4248

Figure 22. ANOVA Results for Average Average Short Tons Delivered as the Response Variable

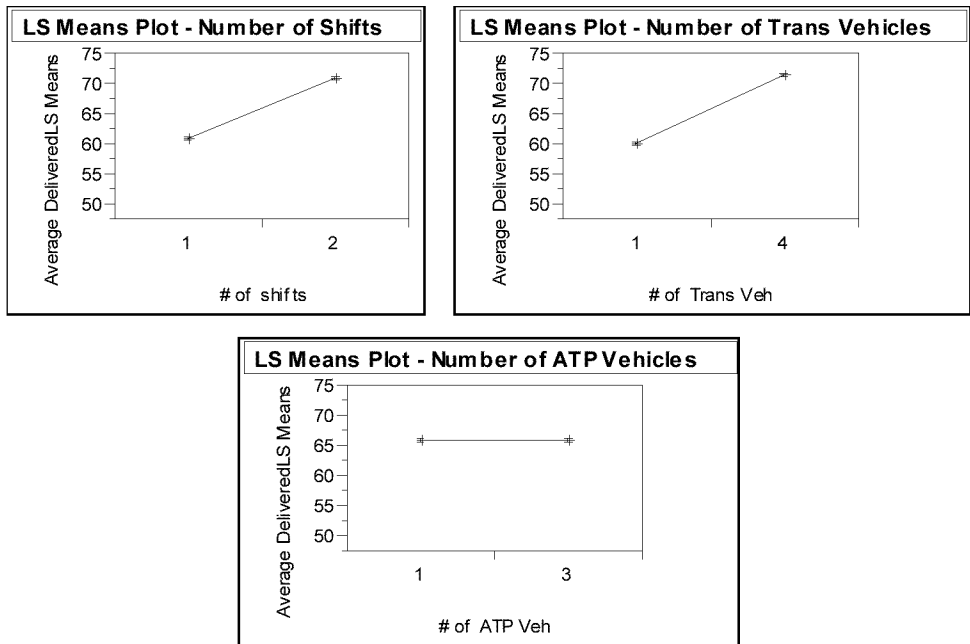

Figure 23. Average Short Tons Delivered Main Effects LS Means Plots

Vehicle plots are also very similar to the throughput plots in Figure 19. A look at the lone significant interaction plot shows another similarity. Similar to the throughput experiment, the interaction effect between the number of shifts and the number of vehicles from the Transportation Platoon is much larger with one trans vehicle available to the ATP system. The plot for this interaction effect is listed in Figure 24. Here again we see a minimal change in our response variable for the different number of shifts when there are four transportation platoon vehicles available to the ATP system. The similarity in findings leads us to believe that average throughput and average order to issue times are highly correlated. Our last test looked at the ATP system focusing on the footprint and the maximum number of CROPs in storage at one time.

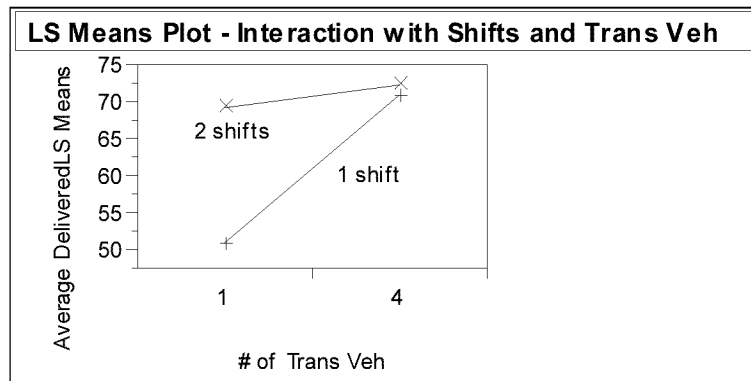

Figure 24. Average Order to Ship Times Interaction Effects LS Means Plots

The Results – Mean Maximum CROPs Stored as the Response Variable

The third experiment discussed uses the mean maximum CROPs stored as the response variable with all three factors at two levels. Unlike the other performance measures, the mean maximum CROPs stored response aims toward lower numbers, in other words, smaller is better. Results are also taken from JMP using an alpha value of

.05. Figure 25 shows the treatment means for all factor level combinations. Glancing at the numbers, we see a huge disparity between systems with one trans vehicle and those systems with four trans vehicles. This result makes sense in that the number of CROPs stored will always depend on the systems ability to deliver the CROPs to the customer.

Number of Shifts		1		2	
Number of Trans Vehicles		1	2	1	2
Number of ATP Vehicles	1	73.97	9.20	15.43	9.07
	2	74.67	8.83	15.33	9.53

Figure 25. Mean Maximum CROPs Stored

Figure 26 displays the treatment means for all the factor level combinations for the time weighted average number of CROPs stored in the ATP. These numbers tell us the average number of CROPs stored in the ATP at any given time. We see a close relationship between this measurement and the average maximum number of CROPs

Number of Shifts		1		2	
Number of Trans Vehicles		1	2	1	2
Number of ATP Vehicles	1	37.26	3.88	7.50	2.14
	2	37.64	3.55	7.44	2.64

Figure 26. Time Weighted Average Number of CROPs Stored

stored as expected. Again, we see a tremendous difference in number of CROPs stored in the ATP and the significance of the interaction between the number of trans vehicles available and the number of shifts operating. At the low end of our settings with one shift and one trans vehicle available, the footprint for the ATP is enormous with an average of about 38 CROPs stored; however, looking at our base case scenario with all resources available to the ATP, we see only about three CROPs in storage—a much more

manageable level. The discussion now continues with a third analysis of variance for the mean maximum number of CROPs stored.

Figure 27 displays the results of the third ANOVA. Looking at the p-values provided, we see that, like the average throughput analysis, Shifts and Trans Vehicles significantly ($p\text{-value} < 0.05$) affect the average short tons delivered to customer units within the brigade area. Like the other responses, the interaction of Shifts and Trans Vehicles is significant. Using JMP's ability to provide Least Squared (LS) means plots, pictorial views of these effects are provided to help explain the significant effects. Figure 28 shows a set of plots for the three main effects. Recall, that less is better for this response variable.

Summary of Fit	
RSquare	0.992746
RSquare Adj	0.992559
Root Mean Square Error	2.380149
Mean of Response	27.00417
Observations (or Sum Wgts)	240

Analysis of Variance				
Source	DF	Sum of Squares	Mean Square	F Ratio
Model	6	180633.02	30105.5	5314.195
Error	233	1319.97	5.7	Prob > F
C. Total	239	181953.00		<.0001

Effect Tests					
Source	Nparm	DF	Sum of Squares	F Ratio	Prob > F
# of shifts	1	1	51597.338	9107.913	<.0001
# of Trans Veh	1	1	76433.704	13492	<.0001
# of shifts*# of Trans Veh	1	1	52599.204	9284.762	<.0001
# of ATP Veh	1	1	1.837	0.3244	0.5696
# of shifts*# of ATP Veh	1	1	0.004	0.0007	0.9784
# of Trans Veh*# of ATP Veh	1	1	0.938	0.1655	0.6845

Figure 27. ANOVA Results for Maximum CROPs Stored

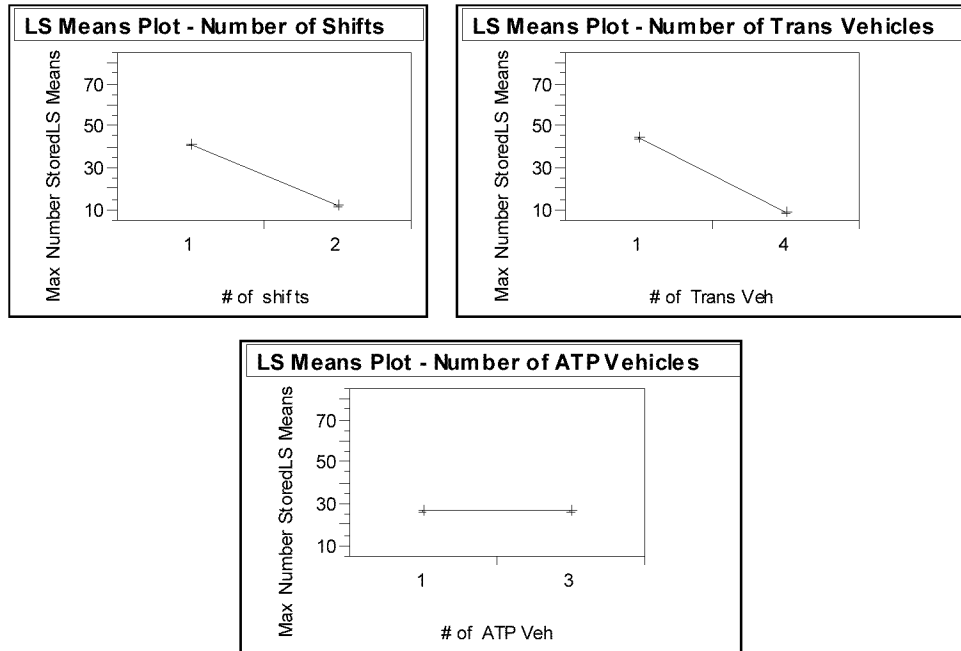

Figure 28. Average Maximum Short Tons Stored Main Effects LS Means Plots

The results for this experiment emulate those from the throughput and delivered experiments. Again, we see the flat slope associated with the ATP Vehicles effect. The Shifts and Trans Vehicle plots display better performance under the higher level settings. These results make sense and serve to verify the simulation. A look at the shifts and trans vehicle interaction plot shows another similarity. Like the throughput experiment, the interaction effect between the number of shifts and the number of vehicles from the Transportation Platoon is significant only with one trans vehicle available to the ATP system. The plot for this interaction effect is displayed in Figure 29. These findings lead us to believe that our response variables average throughput, average delivered, and average maximum CROPs stores are correlated.

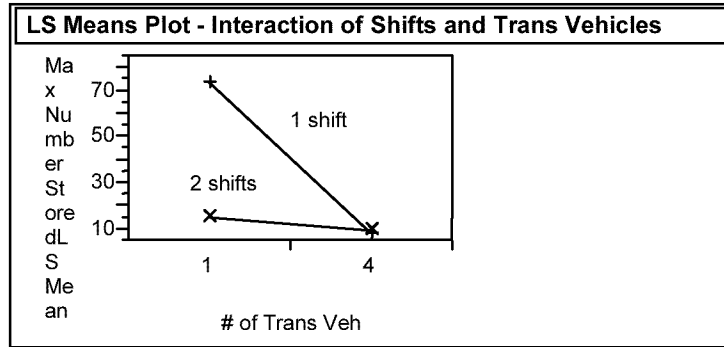

Figure 29. Average Maximum CROPs Stored Interaction Effects LS Means Plot

To test our hypothesis, we used JMP's Bivariate Fit Model to see how strong the correlation is between our response variables. Figure 30 shows the relationship between

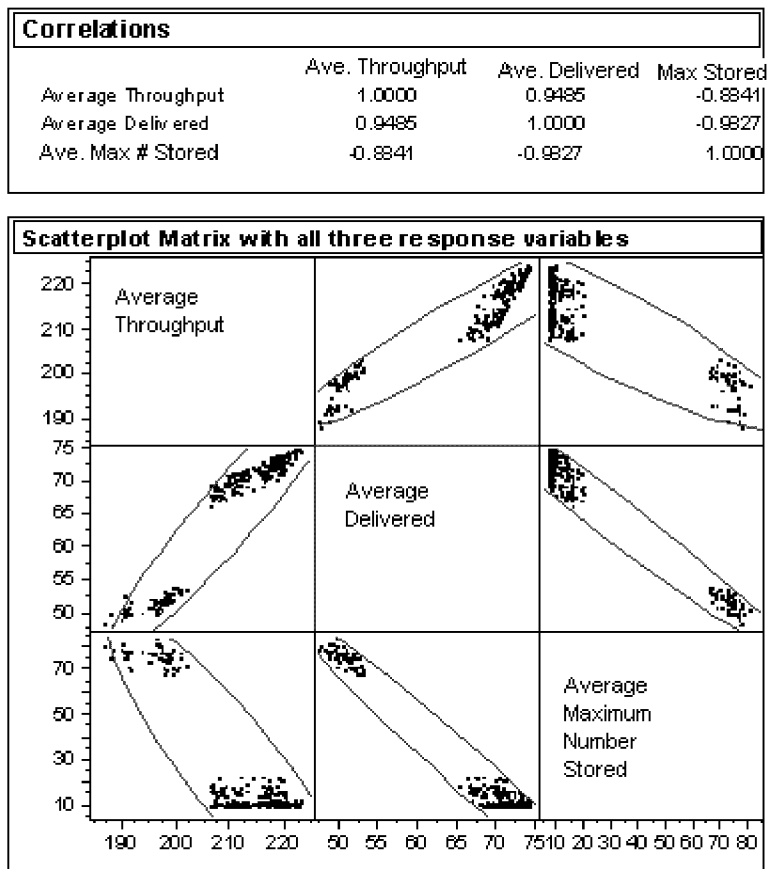

Figure 30. Scatterplot Matrix for the Performance Variables

the three response variables. As expected, we see a high correlation between our responses. The correlation values given are the Pearson correlation coefficients for each pair of variables as provided by JMP. If there was an exact linear relationship for each pair, the correlation coefficients would all equal 1. If there were no relationship, the correlation coefficients would tend toward zero. We see that all response variables are highly correlated with one another either negatively or positively depending on the pair of response variables considered. As such, the ANOVA outputs should mirror each other as we have seen thus far. The correlation test results continue to support the verification of our model. The performance measure relationships in Figure 30 all support the real-world relationships we would expect from an ATP operation.

Overall Findings

The experiments accomplished the primary task to predict the ATP's ability to meet the 138 STONs per day goal for throughput. As we observed, for the information input into the model, the base case system will easily meet the 138 STON surge level for system throughput. We also uncovered the factors and interactions that influence the performance of the ATP, while verifying that the ATP model is working properly.

Understanding that “main effects do not have much meaning when they are involved in significant interactions,” (Myers and Montgomery; 1995: 106) our analysis uncovered the important interaction between the number of shifts and the number of transportation platoon vehicles available to the ATP operation. This important interaction tells us that throughput is very dependent upon the delivery operation. The receipt and storage processes within the ATP are important, but the significant operation

is the delivery process. The results show that with two shifts and an assumed 24-hour delivery schedule, one transportation platoon truck can maintain the proper flow of ammunition to customer units. Also worth noting is that with only one shift at the ATP, the four transportation platoon assets can also meet demands during the daylight hours and limited evening delivery schedule.

Also revealed from the factor analysis is the lack of significance of the ATP vehicles. Given the information regarding the tasks and operations from the subject matter experts, the three organic HEMTT-LHS vehicles modeled were used for only the first ten days of the operation. The assets were needed for trans-loading shipments from host nation support assets delivering CROPs from theater ports. The model assumed that the echelon of U.S. Army units assigned to support the IBCCT after day ten would also be equipped with the Load Handling System. Within the model, no other tasks were assigned to the ATP HEMTT-LHS vehicles. Assuming these concepts are true, the ATP vehicles will not significantly influence ATP operations. These results highlight the significance of the assumptions made for the ATP model. If these assumptions do not hold true, adjustments should be made to the model and the experiments should be rerun. Several comments were made throughout the chapter regarding the verification of the ATP model. In addition to providing some insight into the significant factors or interactions of factors associated with ATP operations, the experiments conducted also helped solidify the internal credibility of the ATP model. If one considers the assumptions made while developing the ATP model, the results found make sense and could be considered realistic outcomes of a real-world system (validation efforts comparing the model with an actual ATP system would confirm or deny this judgment).

Overall, the experiments increased our understanding of the ATP operation and improved our confidence in the ATP model as an approximation to the actual system. The analysis also revealed the complexity of the ATP system. As stated earlier, the inputs made during the development of the model will require additional validation with an actual ATP in operation. The final chapter follows with a recap of our study and a discussion concerning future uses of the ATP model for further system understanding.

V. Conclusions and Recommendations

Overview of Research

To combat today's full spectrum of threats against our nation and our allies, a need exists for a new force structure able to quickly deploy with an extensive array of resources capable of deterring the opposition promptly and achieve outcomes supporting strategic objectives. To get there from here, the Army must transform from its current cold-war configuration into a full-spectrum capable and more responsive military of the future. Established to develop the land force of the future, the Army Transformation Campaign Plan (ATCP) includes one of the Army's answers to this requirement—the Interim Brigade Combat Team.

To achieve this new organization, the Army has commenced a Revolution in Military Affairs (RMA). The RMA seeks to leverage new technologies to provide the future force with the ability to visualize, maneuver, and understand the battlefield like no other in history. To deploy and sustain the future ground force and compliment the RMA, the Army has also launched the Revolution in Military Logistics (RML). The RML also makes the most of new technologies to automate support activities, improve communications, and minimize the logistics footprint. The revolution in military affairs is motivating massive changes. These changes will call for combat developers to use quantitative analysis tools to improve their understanding of objective force units and ultimately ensure the proper design to effectively support the dynamic battlefields of the future.

Like all forces throughout the history of warfare, the future force will continue to rely upon the ammunition supply chain to effectively prosecute war. Unlike any other battlefield commodity, ammunition influences the outcome of engagements. As such, on going analysis of the ammunition supply chain is important to ensure the success of the future force. This study focuses on the ammunition distribution for a stand-alone interim brigade combat team for an initial entry scenario within its assigned area of operations. The organization responsible for ammunition handling and distribution is the Headquarters and Distribution Company (HDC) of the Brigade Support Battalion. Within the HDC, the Supply Platoon's Ammunition Transfer Point (ATP) section is designed to receive, store, and issue ammunition to all units within the IBCT; while the distribution mission relies on the Transportation Platoon of the HDC. Together, these platoons handle 100% of the ammunition required for the IBCT units. This study takes an in-depth look at the resources and activities of these platoons to provide increased understanding of the ammunition distribution system's capabilities.

Relevance of the Research

This work is one example of on-going efforts to improve our understanding of the IBCT and its support infrastructure. We began with the goal of developing a discrete-event simulation model of the IBCT's ATP to create a "virtual ATP" for factor analysis and performance prediction. Many of the benefits of discrete event simulation were realized. Built in Arena 5.0, the model features a complete animation of the ATP system capturing the realistic movements of resources and ammunition stocks expected in future IBCT operations. The model development process relied on the opinion of subject matter

experts from the Army's logistics community, current doctrine, and scenario-based training materials used to develop future leaders of IBCT units. As such, the model captures many realistic characteristics of a future IBCT operation and provides predictions of system output and reveals factors influencing system performance. The statistical analysis conducted also verifies model accuracy. Other verification techniques were used to ensure confidence in model outputs. Besides providing information on the ATP system, this work introduces a methodology for continued IBCT unit analysis and reveals the impressive capabilities of Arena's discrete-event simulation modeling software.

Results of the Research

Our efforts provide important information regarding the throughput capability of the current ATP design and also reveal some interesting information regarding the factors influencing system performance. The analysis of the base case or current configuration of the ATP revealed that it is capable of handling the projected surge capacity of 138 STONs per day. The analysis shows (given the model assumptions and inputs) that the system will easily handle more than the current expected daily amounts of ammunition. In addition, the analysis uncovered the important interaction between the number of shifts and the number of transportation platoon vehicles available to the ATP operation. This important interaction tells us that throughput is very dependent upon resources and activities associated with the *delivery* operation. The resources associated with the receipt and storage of ammunition are obviously essential, but their influence on the total system throughput is not as great as the vehicles from the transportation platoon or the

ammunition handlers preparing the ammunition loads for delivery. The results show that with two shifts and an assumed 24-hour delivery schedule, one transportation platoon truck can maintain the proper flow of ammunition to customer units. Also worth noting is that with only one shift at the ATP, four transportation platoon vehicles can also meet demands during the daylight hours and limited evening delivery schedule.

The factor analysis also revealed the lack of significance of the organic ATP vehicles. Given the information collected regarding the tasks and operations assigned to the ATP assets, the three organic HEMTT-LHS vehicles modeled were used for only the first ten days of the operation. The assets were needed only for trans-loading shipments from host nation support assets delivering CROPs from theater ports. The model assumed that the higher echelon of U.S. Army units assigned to support the IBCT after day ten would also be equipped with the HEMTT-LHS and therefore would be capable of parking CROPs into storage areas without the ATP vehicle's assistance. No other tasks were assigned to the ATP HEMTT-LHS vehicles. Assuming these concepts are true, the ATP vehicles will not significantly influence ATP operations.

A final note concerning the results of the research involves the definition of the performance measure used for the ATP referred to as throughput. Currently, throughput is defined as the amount of ammunition received, stored, and issued from the supply node on a daily basis. While this measurement addresses all functions associated with supply point activities, it greatly inflates actual system performance and misguides logistics managers seeking optimal performance. Many organizations have learned the lesson that misguided performance measures will eventually lead subordinates away from globally optimal system performance. While receipt and storage activities are valuable and

essential to customer support, they fail to direct efforts towards the true measure of success for the ATP operation. The issue of stocks is a more accurate measure, but still fails to completely capture system success. Adopted from Eliyahu Goldratt's theory of constraints philosophy, the amount *delivered* to customers reveals true system throughput and provides managers with a more global view of ammunition supply chain performance. Understanding that this measure cuts into several distinct functions in today's uncoupled supply chain infrastructure, this measure of throughput will facilitate multi-functional management of the future's distribution-based logistics and ultimately provide all members of the support team with the customer-focus and responsiveness now experienced at many world-class civilian firms.

Future Research

Critical information regarding consumption data for the IBCT within small-scale contingency operations was unavailable for this analysis. More ammunition consumption data needs to be collected in order for this model and future supply chain models to maximize their utility. The consumption rates used in this model were purposely set at a level assumed to exceed the levels one would expect for a SASO scenario. Once new consumption information is developed, the model should incorporate those changes and the experiment should be conducted again.

To increase the validity of the model, actual process time data should be collected and compared to the activity parameters used within the model. Current times for receipt and storage activities seem short; a check for each process time is recommended.

Further research efforts should also be applied toward the distribution piece of the IBCT's entire supply chain. A transportation-centered model should focus on the distribution of ammunition from the continental United States through the relevant supply chain nodes and finally to *all* IBCT units possibly down to a company level. This study revealed the significance of the distribution process associated with ATP operations, an additional study may uncover other sources of problems in the distribution process (bottlenecks) that may affect the global ammunition supply chain.

Retrograde or returns from customers as a result of inaccurate configured loads may have an adverse effect on ATP operations. Following subject matter expert opinion (Ellison and Hale; 2002), the level of retrograde CROPs for this study was set relatively low and did not impact the performance of the ATP. Future studies could look at higher levels of inaccuracy with incoming configured loads producing high levels of returns and measure the impact on the ATP. The study should provide the ammunition community with a better understanding of the configured load concept and its impact on the munitions supply chain.

This work can be used in conjunction with other simulations studies now ongoing. Currently, Mr. Alan Santucci at the U.S. Army Tank-Automotive & Armaments Command Logistics Research and Development Activity is modeling an ammunition corps storage area (CSA) to determine the throughput capability of the CSA. That model is also in Arena 5.0, which should facilitate model integration.

We hope that future researchers will continue in the efforts already on going in this interesting and important area. We sincerely hope this research adds to the combat development community's efforts towards shaping the Army's future force.

Appendix A. The Arena Simulation Model

Demand Sub Models for the FA, ENG, and INF Customers. The “ALTER” nodes serve as gates triggering the receipt of a customer demand.

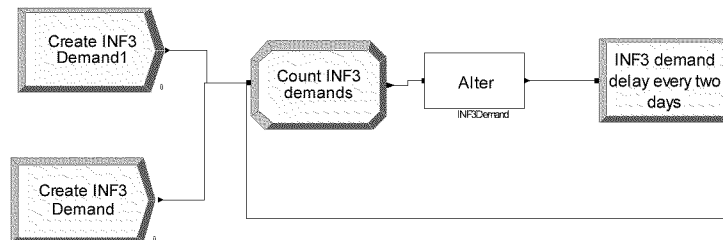
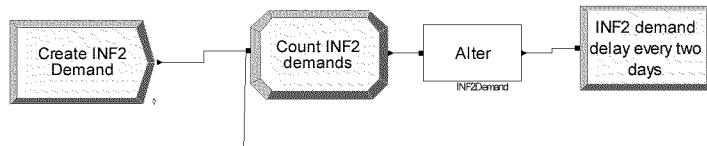
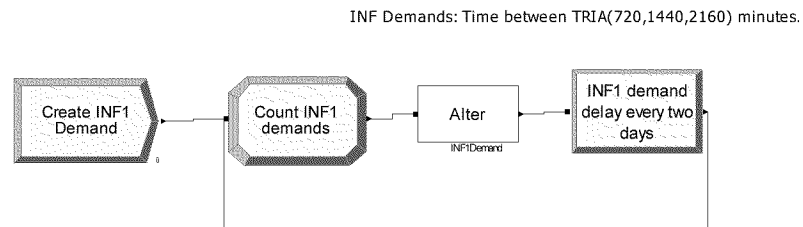
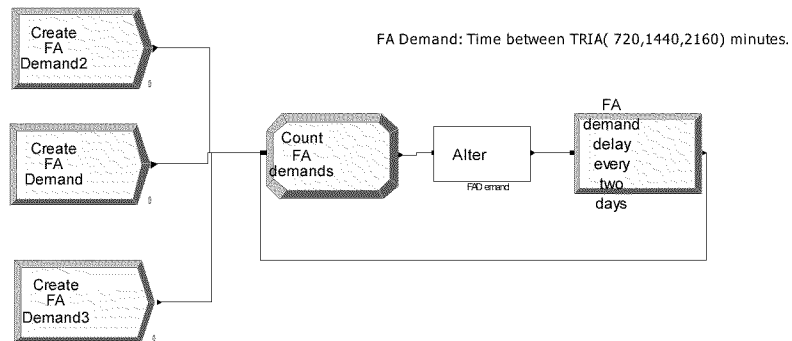
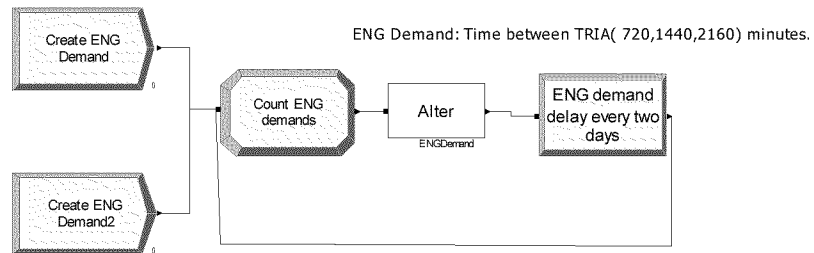

Demand Sub Models for the RSTA and OTHER Customers. The “ALTER” nodes serve as gates triggering the receipt of a customer demand.

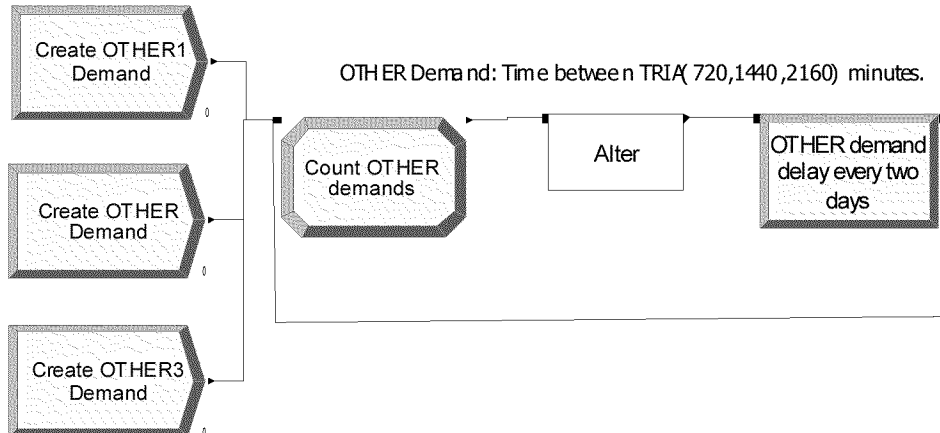
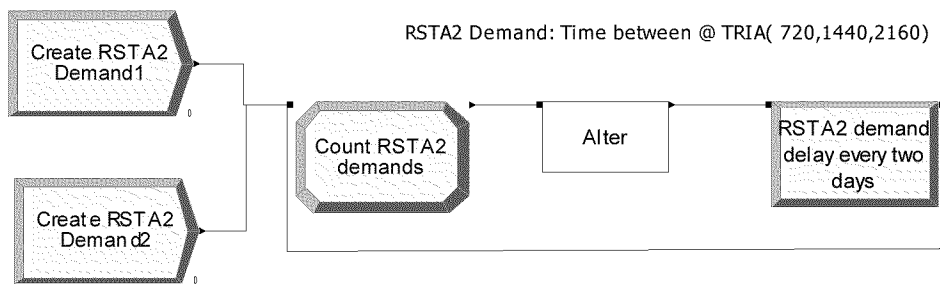
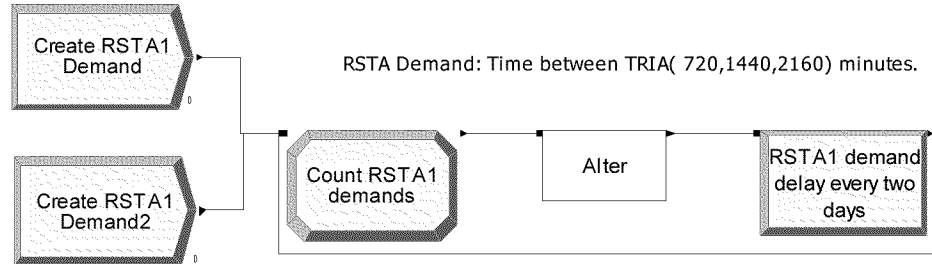

These logic sub-models control the assets for delivery from the APOD to the ATP.

LOGIC SUB_MODEL TYPE #2: These sub models control the percent of US Trucks delivering to ATP First 10 days = 100% host nation support and time between alerts = 4320 min. Days 11 to 30 = 100% us army support (CSSC company)

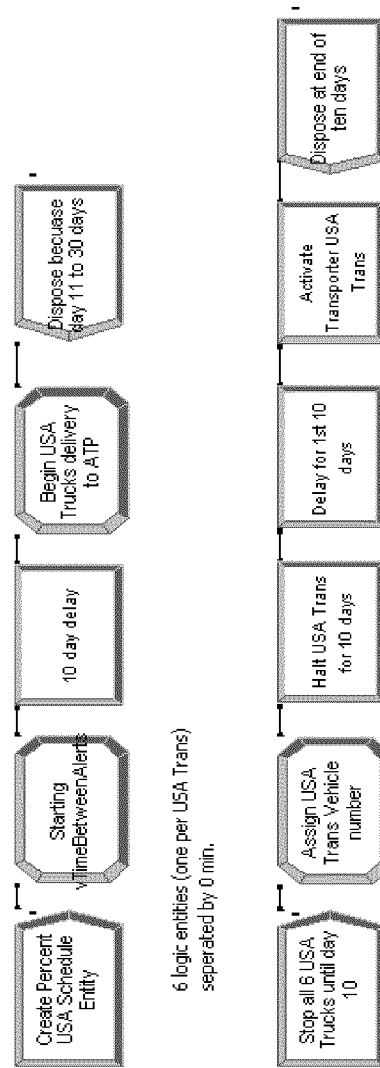

These sub-models control the reliability of HEMTT-LHS vehicles for the ATP section and the transportation platoon of the HDC.

LOGIC SUB-MODEL TYPE #3: These sub models control the reliability of each type of ATP and trans platoon transporter.

Headquarters and Distribution Company Trans Platoon Assets: We start with a given mean miles between failures of 2,300 hours. Using an average rate of 35 KM per hour, we calculate the mean time between failures. For repair times, we used a 2 hour median time with Tria (60,120,240) minutes.

Four logic entities (one per Trans Platoon LHS) separated by 1440 min.

Operating Times: EXPON(15840) min. = 11 days

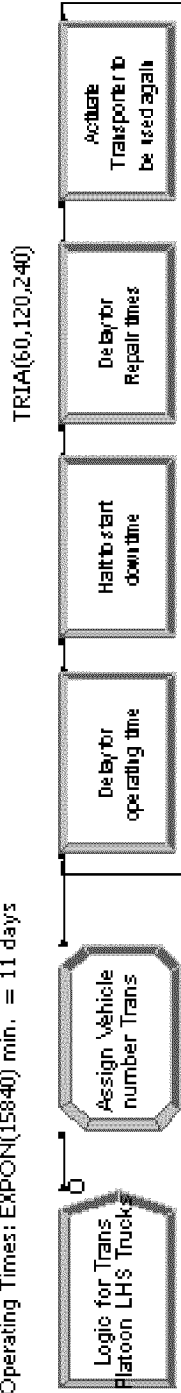

ATP Trans Assets: We start with a given mean miles between failures of 2,300 hours. Using an average rate of 5 KM per hour, we calculate the mean time between failures. For repair times, we used a 2 hour median.

Three logic entities (one per ATP LHS) separated by 2880 min.

Operating Times: EXPON(60000) min. = 45 days

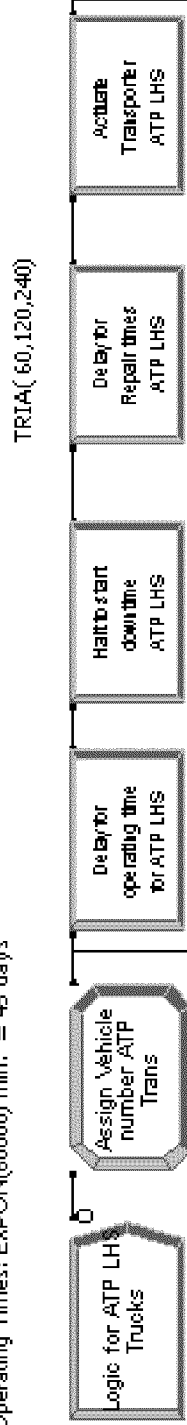

These sub-models show the retrograde logic with the retrograde model from the sub-level of Arena.

LOGIC SUB-MODEL TYPE #4: Creates retrograde activities for the ATP personnel and equipment.

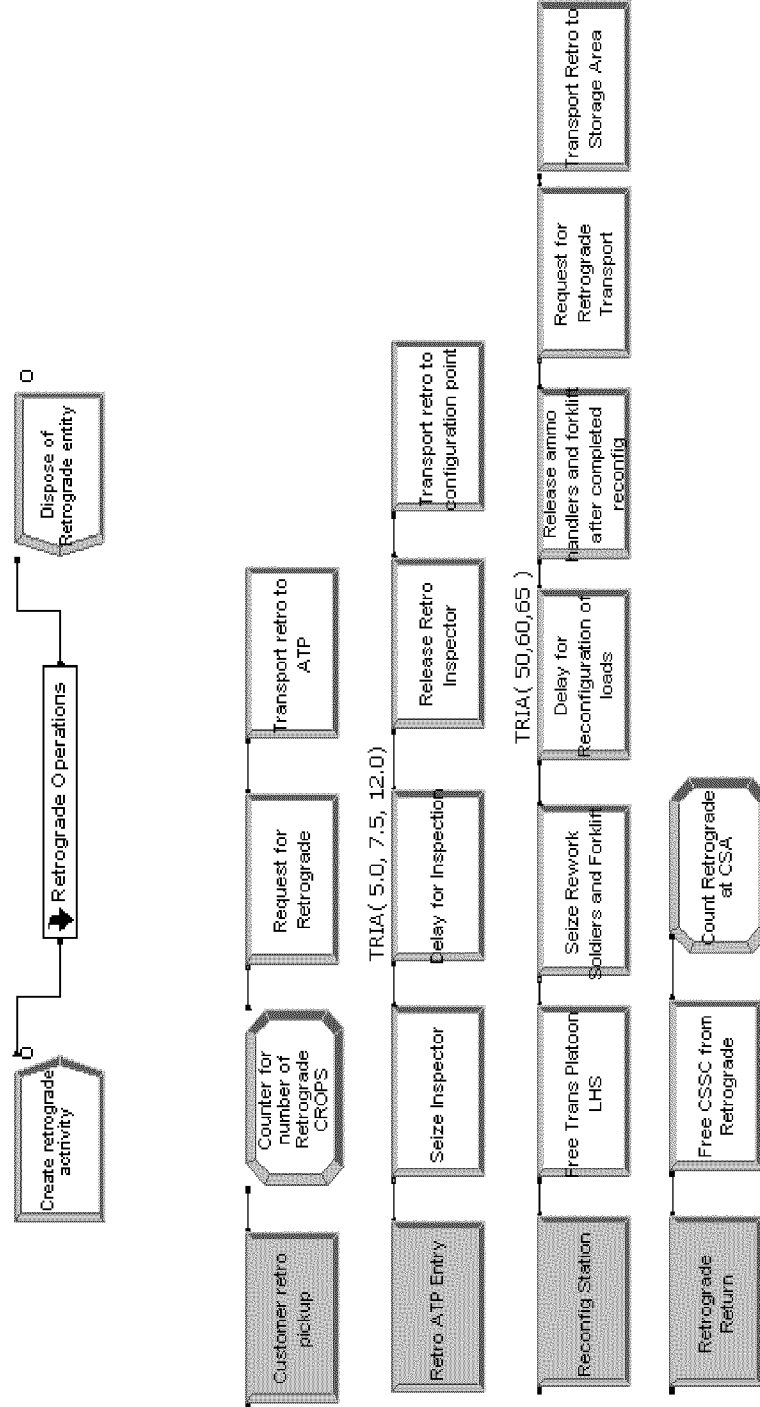

These sub-models are data collection routines. One collects data for daily operations and the other tabulates data for the month.

LOGIC SUB-MODEL TYPE #5: Data collections and write to ascii file.

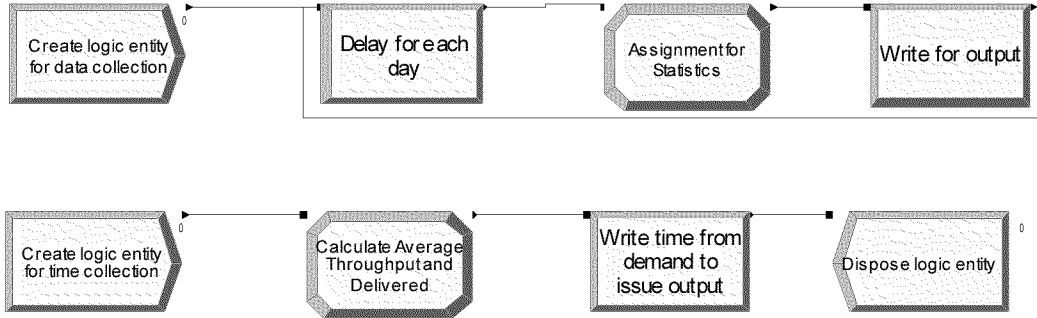

The display below shows the arrival of the aircraft, which actually triggers the main model for the ATP operation.

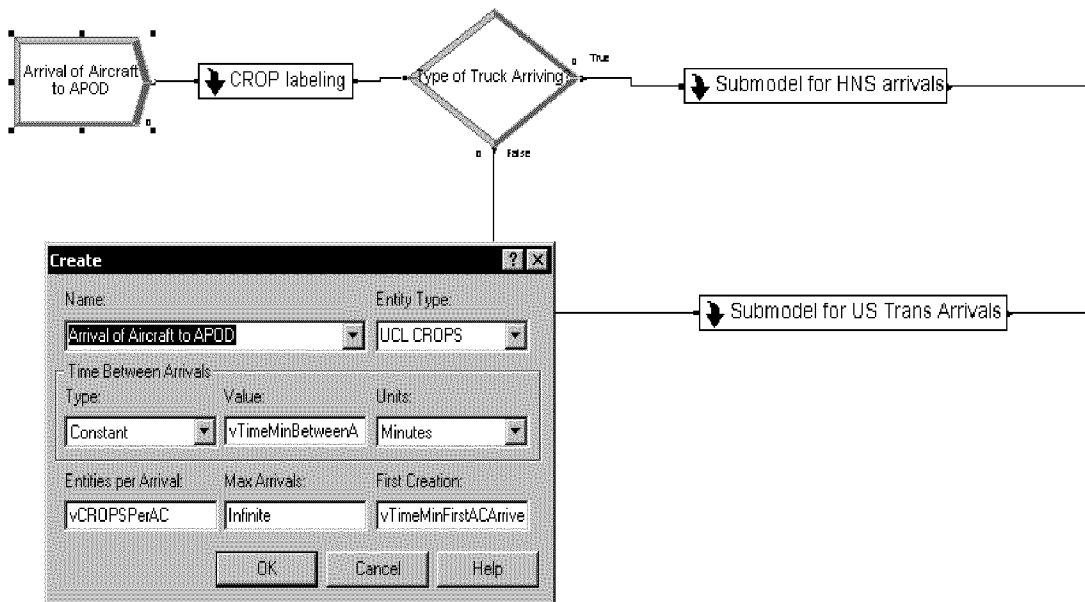

This is the “CROP Labeling” sub-model located in the second level of the ATP model.

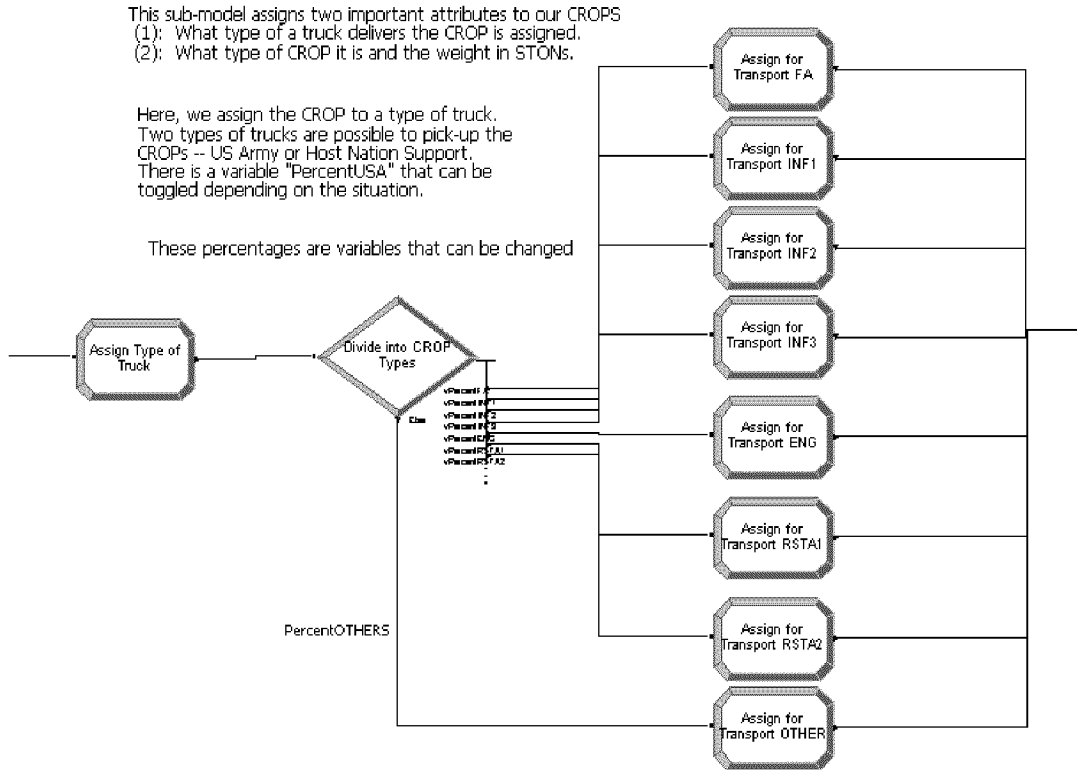

This is the Host Nation Support sub-model located in the second level of the ATP model.

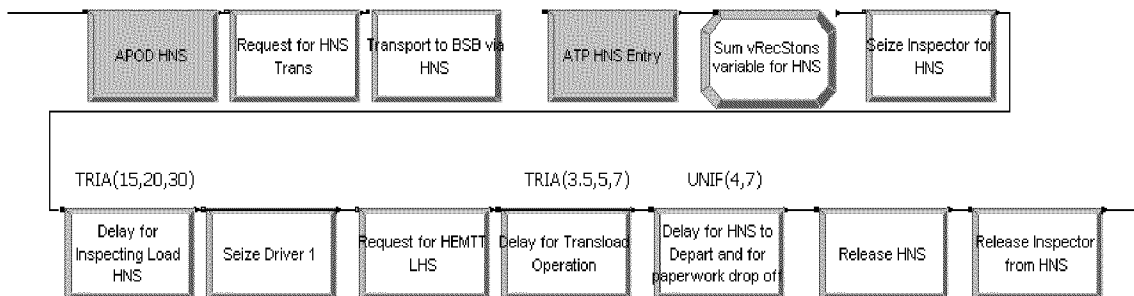

This is the US Transportation sub-model located in a second level of the ATP model.

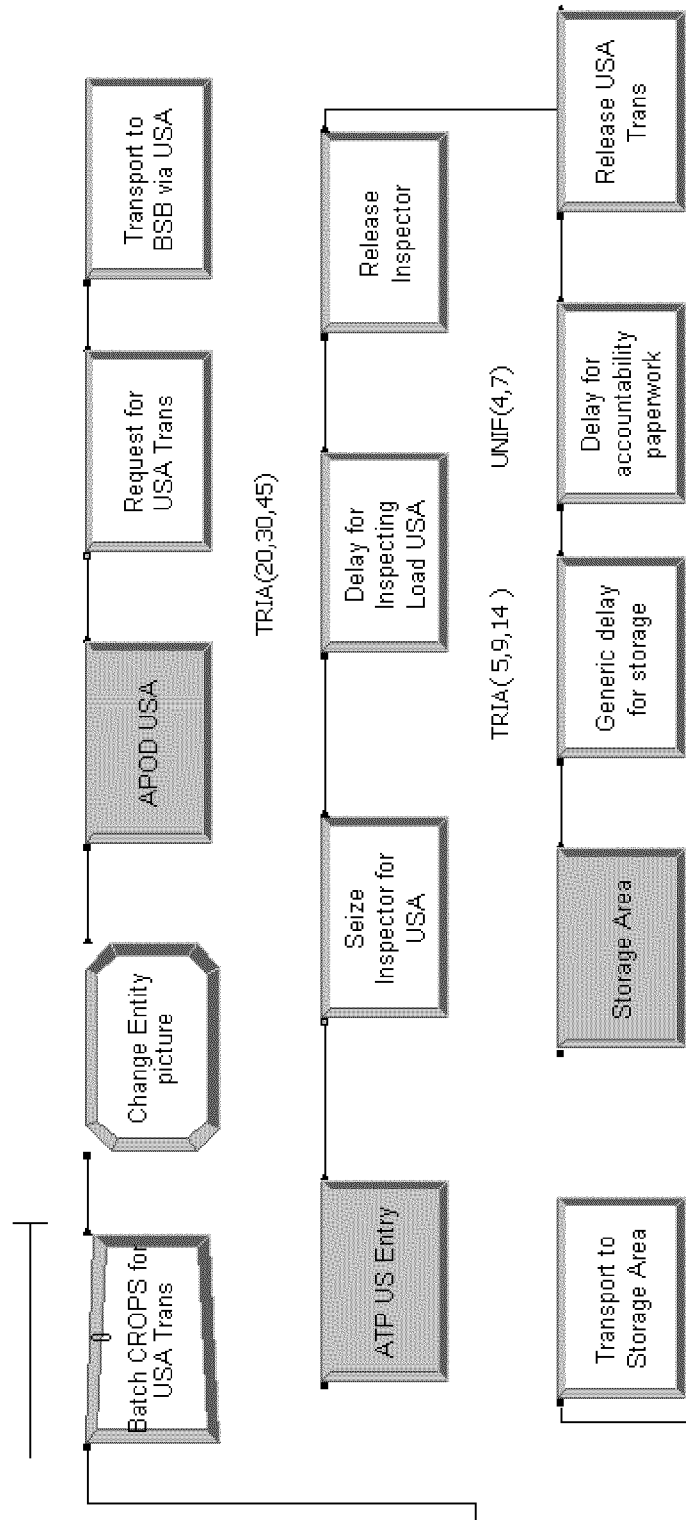

This view of the model shows the logic for FA CROP storage, issue, and delivery to FA customers.

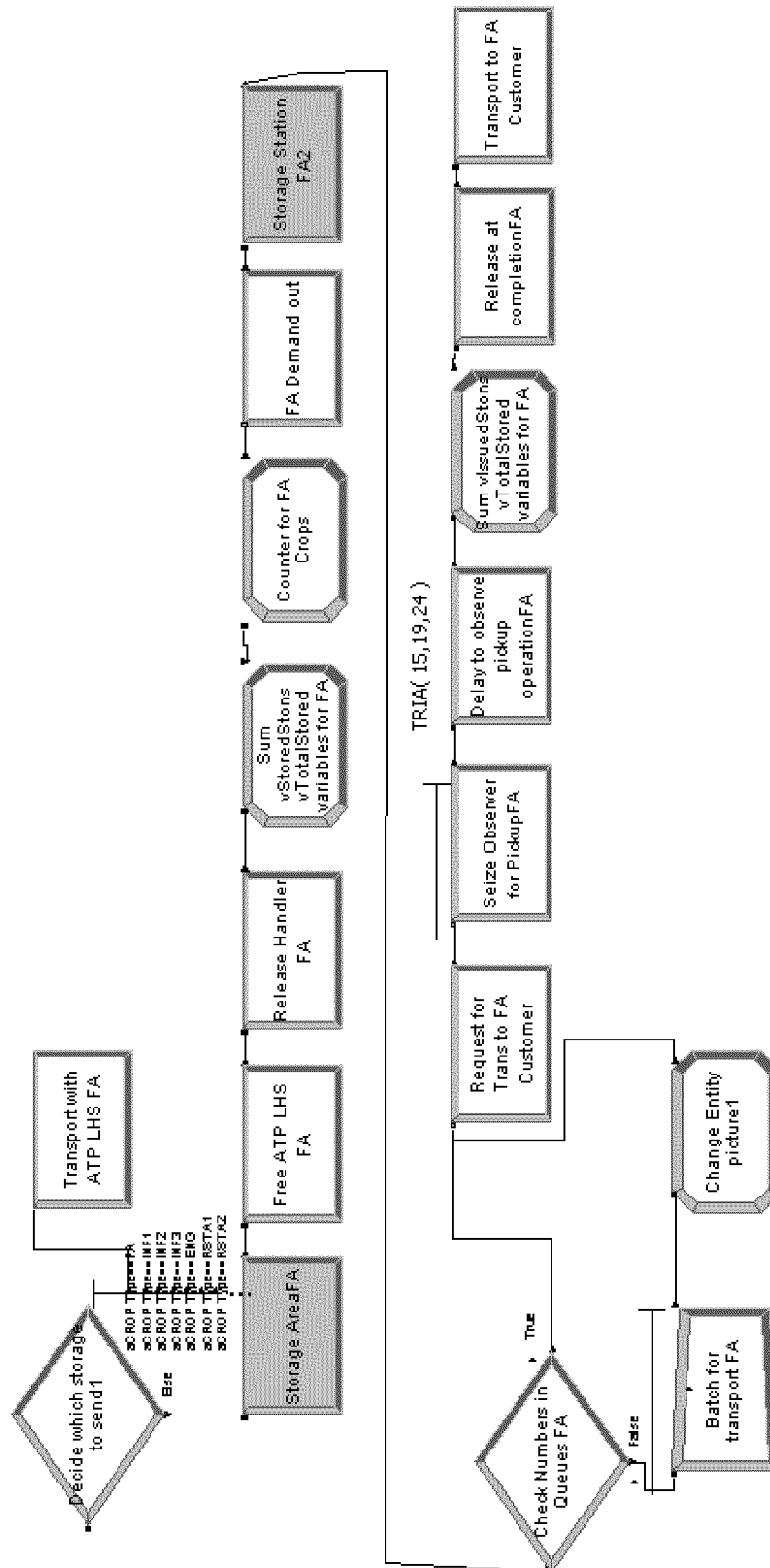

Model Animation: This view shows the animation of the aerial port of debarkation used for our analysis.

APOD

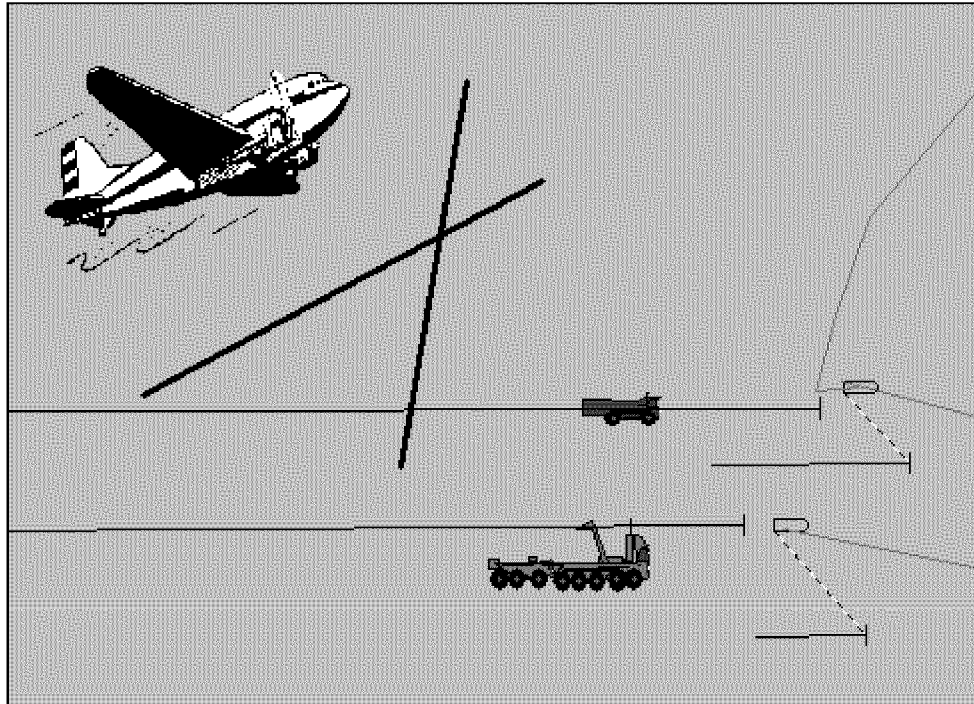

This picture shows the host nation support truck and the HEMTT-LHS assumed as the equipment used by the echelon above brigade unit to deliver to the ATP.

This view shows the ATP storage site for our animation—from the six soldiers per shift to the forklifts and the by-unit storage locations. There are three HEMTT-LHS not pictured assigned to the ATP.

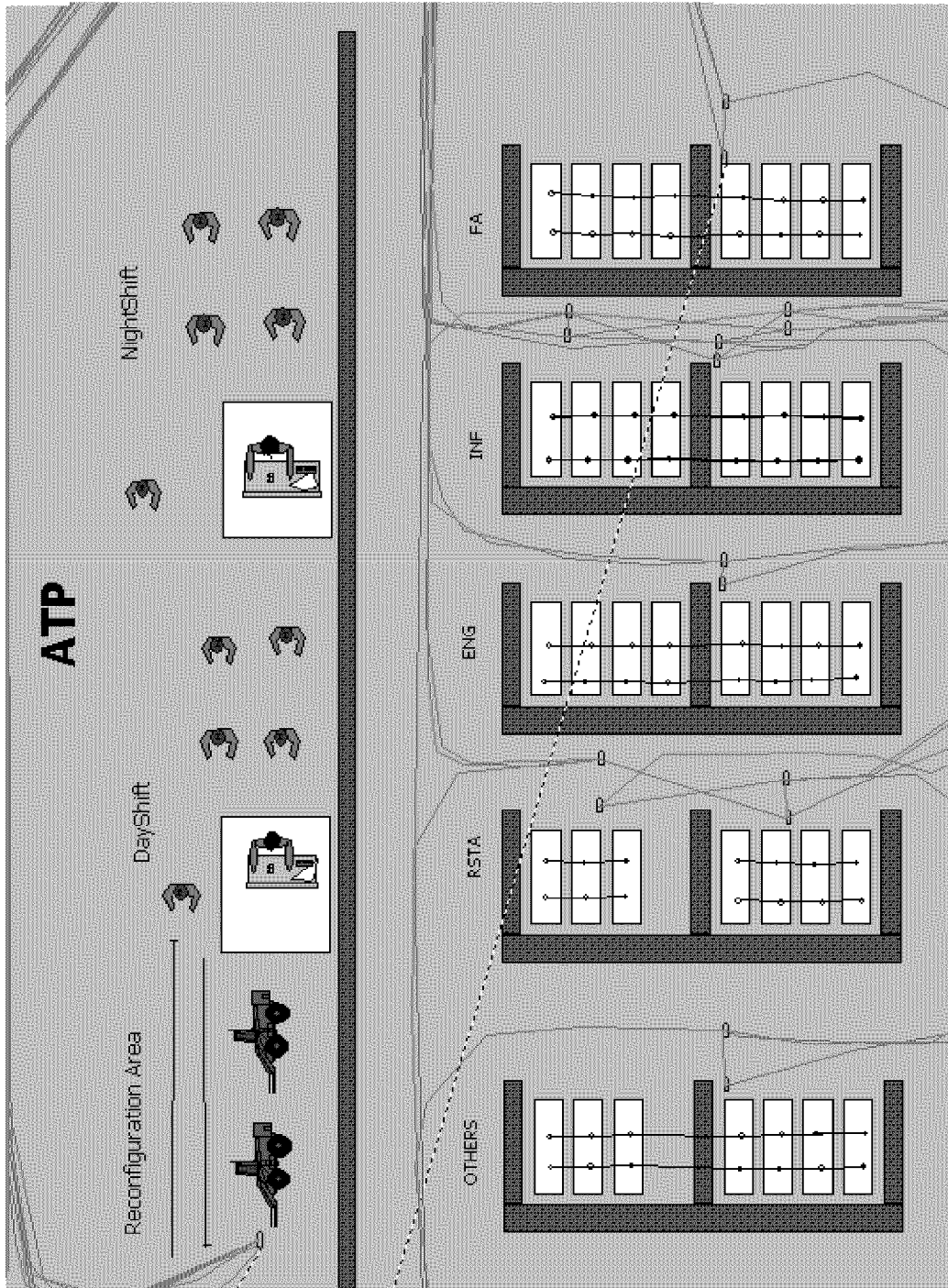

This view shows the customer spread used for the distribution animation for the model. Eight customers are used. A HEMTT-LHS from the transportation platoon is shown moving towards a customer. The boxes tabulate the amount of ammunition delivered in Stons.

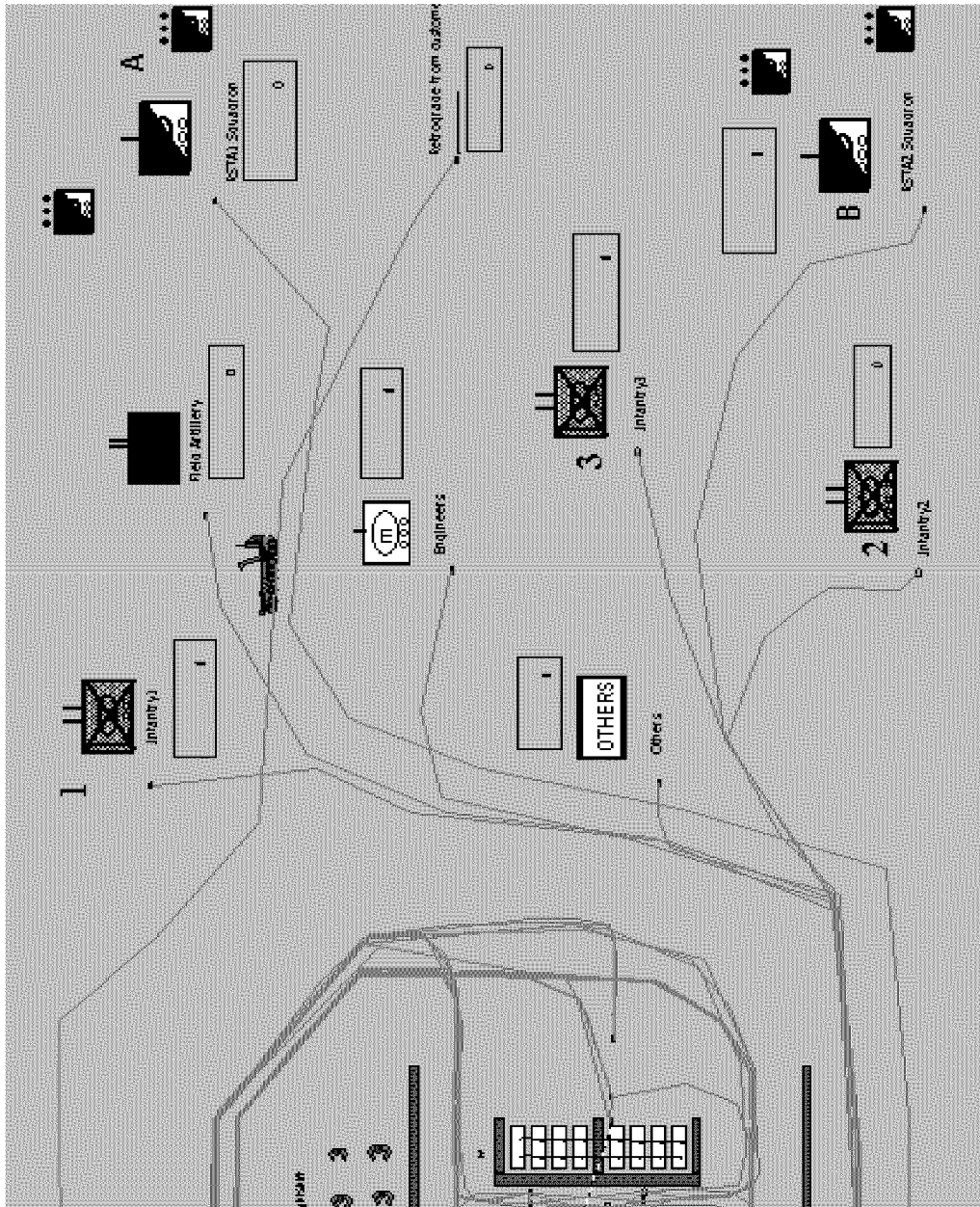

Appendix B. Model Distances

The distances provided below represent the global picture of our battlefield. Arena requires very detailed information for all possible from / to locations for all transporters. The actual model has *three* spreadsheets of distances for the transporters used. The sheets are located in the Advanced Transfer Template under the Distance spreadsheet listing.

FROM / TO LOCATIONS	MODEL DISTANCES (METERS)
General Distances	
Aerial Port (APOD) to ATP	35,000
Transportation Platoon Area to ATP	500
ATP to Echelons above Brigade Retrograde Turn-in Point	22,000
ATP Distances	
Entrance to FA Storage Area	195
Entrance to INF Storage Area	205
Entrance to ENG Storage Area	215
Entrance to RSTA Storage Area	225
Entrance to OTHERS Storage Area	235
Entrance to Reconfiguration Station	75
Customer Distances	
ATP to FA Customer	15,000
ATP to INF 1 st Battalion Customer	10,000
ATP to INF 2 nd Battalion Customer	30,000
ATP to ENG Customer	22,000
ATP to RSTA 1 st Troop Customer	54,000
ATP to RSTA 2 nd Troop Customer	50,000
ATP to OTHER Customers	3,000

Appendix C. IBCT/Objective Force Acronyms and Abbreviation Helper

(Born; 2000)

-A-

AAN	Army After Next (The Army After Next Project envisions what the Army might look like in 30 years and identifies technologies for future research and development today.)
AO	Area of Operations
APOD	Aerial Port of Debarkation
APOE	Aerial Port of Embarkation
ASP	Ammunition Supply Point
ATCP	Army Transformation Campaign Plan
ATP	Ammunition Transfer Point; Allied Tactical Publication

-B-

BAO	Brigade Ammunition Officer
BCT	Brigade Combat Team
BSA	Brigade Support Area
BSB	Brigade Support Battalion or IBCT Support Battalion
BSC	Brigade Support Company; Base Support Company
BSMC	Brigade Support Medical Company

-C-

CASCOM	Combined Arms Support Command
CCL	Combat Configured Load
CHE	Container Handling Equipment
CL	Configured Load
CONUS	Continental United States
COTS	Commercial Off The Shelf
CROP	Container(ized) Roll-In/Roll-Out Platform
CSS	Combat Service Support
CSSCS	Combat Service Support Control System
CSSC	Combat Service Support Company
CSA	Corps Support Area

-D-

DA	Department of the Army
DCD-CSS	Combined Arms Support Command—Director for Combat Developments for Combat Service Support, Fort Lee VA
DOD	Department of Defense
DOS	Day(s) of Supply
DS ASP	Direct Support Ammunition Supply Point

-E-

EAB	Echelons Above Brigade
EAC	Echelon above Corps
EAD	Echelons Above Division
ECDS	Enhanced Container Delivery System

-F-

FA	Field Artillery
FSA	Forward Support Area
FSC	Forward Support Company
FSMC	Forward Support Medical Company
FSMT	Forward Support Medical Team

-G-

GCSS-A	Global Combat Support System--Army
GMC	Ground Maintenance Company
GPS	Global Positioning System

-H-

HDC	Headquarters and Distribution Company
HEMTT	Heavy Expanded Mobility Tactical Truck (M997)
HEMTT LHS	HEMTT load-handling systems
HHC	Headquarters and Headquarters Company
HQ & DIST CO	Headquarters and Distribution Company
HSC	Headquarters and Support Company

-I-

IBCT	Initial or Interim Brigade Combat Team
ICV	Infantry Carrier Vehicle
IPB	Intelligence Preparation of the Battlefield
INF	Infantry
ISB	(*Intermediate Staging) or Support Base
ISR	Intelligence, Reconnaissance, and Surveillance

-J-

JIT	Just-In-Time-Logistics
JTF	Joint Task Force

-K-

KM (Km)	Kilometer
---------	-----------

-L-

LHS Load Handling System (HEMMT based platform)
LMTV Light Medium Tactical Vehicle
LOC Lines of Communication

-M-

MCL Mission Configured Load(s)
METT-TC Mission, Enemy, Terrain, Troops – Time Available, Civilians
MHE Material Handling Equipment
MIN Minute
MOOTW Military Operations Other Than War (Joint Only)
MOPP Mission Oriented Protective Posture
MSR Main Supply Route
MTBF Mean Time Between Failure
MTTR Mean Time To Repair
MTOE Modified Table of Organization and Equipment
MTW Major Theater War or Major Theaters of War

-N-

NBC Nuclear, Biological & Chemical
NMC Non-Mission Capable

-O-

O&O Operational and Organizational
OST Order to Ship Time

-P-

PLS Palletized Load System (M1074 trailer/M1075 Flatrack)
PLS-E Palletized Load System-Enhanced
PLT Platoon

-Q-

-R-

RACS Regionally Available Commercial Support
RMA Revolution of Military Affairs
RML Revolution Military Logistics
RO/RO Roll-on/Roll-off

-S-

SAAS-MOD	Standard Army Ammunition System - Modified
SASO	Stability and Support Operations
SCL	Strategic Configured Load; Standard Conventional Load
SCM	Supply Chain Management
SPOD	Sea Port of Debarkation
SPOE	Sea Port of Embarkation
SSA	Supply Support Activity
SSC	Smaller Scale Contingencies
SSCO	Small Scale Contingency Operations
STAMIS	Standard Army Management Information System
STON	Short Ton

-T-

TAA	Tactical Assembly Area
TAV	Total Asset Visibility
TC-ACCIS	Transportation Coordinator Automated Command and Control Information System
TC-AIMS II	Transportation Coordinators for Automated Information for Movements II
TCF	Tactical Combat Force
TDD	Time Definite Delivery
TO&E	Table of Organization and Equipment

-U-

UBL	Unit Basic Load
UCL	Unit Configured Load(s)

-V-

VM	Velocity Management
----	---------------------

-W-X-Y-Z-

Bibliography

- Born, Kevin MAJ. Training Developer, Training Directorate, Combined Arms Support Command, Fort Lee, VA. "IBCT/Objective Force Related Acronyms and Abbreviation Helper." 1 August 2000. Available from web address: http://www.cascom.army.mil/mout_Limited/bsb/Acronyms-IBCT.doc
- Carabetta, Joseph J. and Kern, Donald P. Final Report for the Product Verification Test (PVT) of the 10,000-Pound All-Terrain Lifter, Army System (ATLAS). Soldier and Foreign Systems, U.S. Army Aberdeen Test Center, Aberdeen Proving Ground MD 21005-5059, May 1998.
- Cattran, Kevin CW2. Interim Brigade Combat Team Brigade Ammunition Officer, Fort Lewis WA. Electronic mail titled, "ATP Model Information." 20 November 2001.
- Dimensions International, Inc.* "Configured Loads Assessment Report" prepared for the United States Army Logistics Integration Agency, June 2001.
- Ellis, Tom C. MAJ. Combined Arms Support Command—Director for Combat Developments for Transportation, Fort Lee VA. Personal Interview. 15 October 2001.
- Ellison, Kenneth W. MAJ and Hale, David. Combined Arms Support Command—Director for Combat Developments for Ammunition, Fort Lee VA. Personal Interview. 15 October 2001.
- Goldratt, Eliyahu M. *The Goal—A Process of Ongoing Improvement* (2nd Edition). Great Barrington MA: North River Press, 1994.
- *The Haystack Syndrome*. Great Barrington MA: North River Press, 1990.
- Koch, Bruce. LTC. Combined Arms Support Command—Director for Combat Developments for Transportation, Fort Lee VA. Personal Interview. 27 December 2001.
- Law, Averill M. and Kelton, W. David. *Simulation Modeling and Analysis* (3rd Edition). New York NY: McGraw-Hill, 2001.
- Menard, Michael. Combat Development Engineer, United States Army Training and Doctrine Command. Fort Eustis VA. Electronic mail titled, "RE: HEMTT LHS Reliability Data." 15 January 2002.
- Myers, Raymond H. and Montgomery, Douglas C. *Response Surface Methodology; Process and Product Optimization Using Designed Experiments*. New York NY: John Wiley & Sons Inc., 1995.

Neter, John and others. *Applied Linear Statistical Models* (4th Edition). New York NY: WCB McGraw-Hill Book Company, 1996.

Payne, David. "An Elaboration on the Revolution in Military Logistics—A Detailed Description of an Alternative Approach to Military Logistics," A Background Paper for the Logistics Integration Agency (LIA), (January 1999).

Pegden, C.E., Shannon, R.E., Sadowski, R. *Introduction to Simulation using SIMAN* (2nd Edition). New York: McGraw-Hill, 1995.

Phelps, J. C. MAJ. Combined Arms Support Command—Director for Combat Developments for Combat Service Support, Fort Lee VA. "HQDA DCSLOG Container/Materials Handling Equipment Study (C/MHE Study)." Presentation given at Fort Lee VA. 4 April 2001. Presentation available from web address: http://www.cascom.lee.army.mil/Multi/Combat/Container_Materials_Handling_Equipment_Study/CMHE_Study_IPR_Briefings/CMHE_Findings_to_DCSLOG.ppt

Phelps, J. C., MAJ. Combined Arms Support Command—Director for Combat Developments for Combat Service Support, Fort Lee VA. "CMHE Assessment Tool (CAT) Input Data Set - 25." Fort Lee VA. February 2001.

Reimer, Dennis J. "A Note From the Chief of Staff of the Army on the Revolution in Military Logistics," *Army Logistician*, 31: 2 (January-February 1999).

Riddalls, C.E., Bennett, S., and Tipi, N.S., "Modeling the Dynamics of Supply Chains," *International Journal of Systems Science*, 31: 969-976 (2000).

Rockwell Automation, "The Arena Product Family -- a white paper." 30 September 2000. Available at web address: <http://www.arenasimulation.com/pdf/ArenaWhitePaper.pdf>.

Santucci, Alan, United States Army Tank-Automotive and Armaments Command, Advanced Systems Concept Office, Logistics Research and Development Activity. "In-Theater Modeling of Class V Logistics." Presentation to the Theater Distribution Modeling and Analysis Workgroup, Fort Lee VA. 4 October 2001.

Swartz, Stephen, Lt Col (Select), United States Air Force. Assistant Professor, Air Force Institute of Technology, Wright-Patterson Air Force Base OH. Personal Interview. 25 October 2001.

U.S. Department of the Army. 2000. *Interim Brigade Combat Team Organizational and Operational Concept, Chapter 10 (Draft)*. Washington DC: GPO. 13 June 2000. Available at web address: [http://www.cascom.army.mil/mout_Limited/bsb/slc/CSS%20O&O%20as%20of/Chapter%2010%20CSS%20IBCT%20OO%20\(Draft\)%20\(13Jun00\).doc](http://www.cascom.army.mil/mout_Limited/bsb/slc/CSS%20O&O%20as%20of/Chapter%2010%20CSS%20IBCT%20OO%20(Draft)%20(13Jun00).doc)

U.S. Department of the Army. 2000. Field Manual 4-93.7 (63.7), *Combat Service Support to the Interim Brigade Combat Team (Coordinating Draft)* Washington DC: GPO. 30 August 2001. Available at web address:
http://www.cascom.army.mil/multi/fm_4-93.7_coord_draft/index.htm

U.S. Department of the Army Headquarters. 2000. "Soldiers On Point for the Nation: Army Transformation Brief", 17 October 2000. Slides 4-5. Available at web address:
<http://192.111.52.91/resdoc/doctrine/Transformation/TRANSFORMATION.pdf>.

U.S. Department of the Army. Combined Arms Support Command. Scenario Overview. Online. Accessed 11 January 2002. Available at web address:
http://www.cascom.lee.army.mil/Rock_drill/f_IBCT/Rock_Drill_Vignettes.ppt.

Witt, Jeffery D., Feigenbaum, Shawn P. "Extending the Logistics Revolution at the Operational and Tactical Levels," *Army Logistician*, 31: 41 (January-February 1999).

Wyland, B., Buxton K., and Fuqua B. "Simulating the Supply Chain," *IIE Solutions*, (January 2000).

Vita

Captain Todd S. Bertulis was born in Chicago, Illinois, and graduated from Fenton High School in 1987. Todd attended Purdue University in West Lafayette, Indiana and majored in Industrial Engineering. While at Purdue, Todd participated in the Army Reserve Officer Training Program and the Industrial Engineering Cooperative Training Program at American National Can Corporation in Chicago. In 1992, Todd graduated from Purdue University with honors and was commissioned a Second Lieutenant in the United States Army Quartermaster Corps.

Todd entered active duty in April 1993 and his initial assignment was with the 227th Maintenance Battalion, South Korea. Following the tour in Korea, Captain Bertulis was transferred to Fort Bragg, North Carolina where he served in the 82d Airborne Division from September 1994 to February 1997. In March 1997, Todd was assigned to Fort Lee, Virginia where he attended the Combined Logistics Officer Advanced Course. In December 1997, CPT Bertulis transferred to Fort Hood, Texas and was assigned as the 64th Corps Support Group S-3 Plans Officer.

In July 1998, CPT Bertulis assumed command of the 565th Quartermaster Repair Parts Company, 544th Maintenance Battalion, Fort Hood, Texas. CPT Bertulis commanded the 565th until March 2000. Following command, he served as the Operations Officer for the 544th Maintenance Battalion until entering the Graduate School of Engineering and Management, Air Force Institute of Technology in August 2000.

REPORT DOCUMENTATION PAGE			Form Approved OMB No. 074-0188		
<p>The public reporting burden for this collection of information is estimated to average 1 hour per response, including the time for reviewing instructions, searching existing data sources, gathering and maintaining the data needed, and completing and reviewing the collection of information. Send comments regarding this burden estimate or any other aspect of the collection of information, including suggestions for reducing this burden to Department of Defense, Washington Headquarters Services, Directorate for Information Operations and Reports (0704-0188), 1215 Jefferson Davis Highway, Suite 1204, Arlington, VA 22202-4302. Respondents should be aware that notwithstanding any other provision of law, no person shall be subject to a penalty for failing to comply with a collection of information if it does not display a currently valid OMB control number.</p> <p>PLEASE DO NOT RETURN YOUR FORM TO THE ABOVE ADDRESS.</p>					
1. REPORT DATE (DD-MM-YYYY) 03-04-2002		2. REPORT TYPE Master's Thesis		3. DATES COVERED (From - To) August 2001—March 2002	
4. TITLE AND SUBTITLE INTERIM BRIGADE COMBAT TEAM (IBCT) MUNITIONS DISTRIBUTION STUDY			5a. CONTRACT NUMBER		
			5b. GRANT NUMBER		
			5c. PROGRAM ELEMENT NUMBER		
6. AUTHOR(S) Bertulis, Todd, S., Captain, USA			5d. PROJECT NUMBER		
			5e. TASK NUMBER		
			5f. WORK UNIT NUMBER		
7. PERFORMING ORGANIZATION NAMES(S) AND ADDRESS(S) Air Force Institute of Technology Graduate School of Engineering and Management (AFIT/EN) 2950 P Street, Building 640 WPAFB OH 45433-7765			8. PERFORMING ORGANIZATION REPORT NUMBER AFIT/GLM/ENS/02-02		
9. SPONSORING/MONITORING AGENCY NAME(S) AND ADDRESS(ES) Howard Burnette Chief, Materiel Modernization Division United States Army Combined Arms Support Command 3901 A Ave., Suite 220 Fort Lee, VA 23801-1809			10. SPONSOR/MONITOR'S ACRONYM(S) CASCOM, DCD-CSS		
			11. SPONSOR/MONITOR'S REPORT NUMBER(S)		
12. DISTRIBUTION/AVAILABILITY STATEMENT APPROVED FOR PUBLIC RELEASE; DISTRIBUTION UNLIMITED.					
13. SUPPLEMENTARY NOTES					
14. ABSTRACT The Army of the future will need to be able to quickly respond to a full spectrum of conflict—from stability and support operations to major theater wars. Today, military leaders have limited options when reacting to the wide range of current threats existing in our world. The nation needs ground combat units that can deploy very rapidly to stabilize a hostile area while possessing combat capabilities able to terminate a threat if necessary. The Army's answer to this requirement is the Interim Brigade Combat Team (IBCT). This study employs an Arena 5.0 discrete-event simulation model to explore the capabilities of the IBCT ammunition transfer point to determine if the system will perform as predicted—to be capable of meeting a daily throughput level of 138 short tons of ammunition in support of the IBCT. Imposing realistic battlefield variance on the modeled system, a statistical analysis is performed to reveal significant factors influencing ATP system performance.					
15. SUBJECT TERMS Interim Brigade Combat Team; IBCT; Ammunition; Ammunition Transfer Point; ATP; Discrete-Event Simulation; Simulation; Arena; Ammunition Distribution; Supply Chain Management; ANOVA; Analysis of Variance					
16. SECURITY CLASSIFICATION OF:			17. LIMITATION OF ABSTRACT UU	18. NUMBER OF PAGES 112	19a. NAME OF RESPONSIBLE PERSON J.O. Miller, LtCol, USAF (ENS)
a. REPO RT U	b. ABSTRA CT U	c. THIS PAGE U			19b. TELEPHONE NUMBER (Include area code) (937) 255-6565, ext 4326; e-mail: John.Miller@afit.edu